

TECHNICAL MANUAL

DIRECT SUPPORT AND GENERAL SUPPORT

REPAIR PARTS LIST

(INCLUDING DEPOT MAINTENANCE ALLOWANCES)

WINCH ASSEMBLY

(2590-753-8687, 2520-040-2112

HG-W2868D, AND 2590-402-5200

W/CABLE LEVEL WINDER ASSEMBLY)

---

HEADQUARTERS, DEPARTMENT OF THE ARMY

MARCH 1972



**TECHNICAL MANUAL** }  
**NO. 9-3830-206-34P** }

**HEADQUARTERS**  
**DEPARTMENT OF THE ARMY**  
**WASHINGTON, D. C. 6 March 1972**

**DIRECT AND GENERAL SUPPORT**

**REPAIR PARTS LIST**

(INCLUDING DEPOT MAINTENANCE ALLOWANCES)

**WINCH ASSEMBLY (2590-753-8687, 2520-040-2112**

**HG-W2868D, AND 2590-402-5200**

**W/ CABLE LEVEL WINDER ASSEMBLY)**

		Page
<b>SECTION</b>	<b>I. INTRODUCTION .....</b>	<b>1</b>
	<b>II. REPAIR PARTS LIST .....</b>	<b>5</b>
<b>Group</b>	<b>20. WINCH .....</b>	<b>5</b>
	<b>2001 Winch assembly .....</b>	<b>5</b>
	<b>22. ACCESSORY ITEMS .....</b>	<b>32</b>
	<b>2210 Data plates and instruction holders .....</b>	<b>32</b>
	<b>III. FEDERAL STOCK NUMBER AND REFERENCE NUMBER INDEX . . . . .</b>	<b>50</b>



# SECTION I

## INTRODUCTION

### 1. Scope

This manual lists repair parts required for the performance of direct support, general support and depot maintenance of the Winch Assemblies, FSN 2520-040-2112, 2590-402-5200 and 2590-753-8687.

### 2. General

This Repair Parts List is divided into the following sections:

*a. Repair Parts—Section II.* A list of repair parts authorized for the performance of maintenance at the direct support, general support and depot level in figure and item number sequence.

*b. Special Tools, Test and Support Equipment. Not Applicable.*

*c. Federal Stock Number and Reference Number Index—Section III.* A list of Federal stock numbers in ascending numerical sequence followed by a list of reference numbers in ascending alpha-numeric sequence, cross-referenced to the illustration figure number and item number.

### 3. Explanation of Columns

The following provides an explanation of columns in the tabular lists in sections II, III, and IV.

*a. Source, Maintenance, and Recoverability Codes (SMR), Column 1.*

(1) Source Code, indicates the selection status and source for the listed item. Source Codes are—

<i>Code</i>	<i>Explanation</i>
P	Repair Parts, Special Tools and Test Equipment supplied from GSA / DSA, or Army supply system, and authorized for use at indicated maintenance categories.
P2	Repair Parts, Special Tools and Test Equipment which are procured and stocked for insurance purposes because the combat or military essentiality of the end item dicates that a minimun quantity be available in the supply system.
P9	Assigned to items which are NSA design controlled: unique repair parts, special tools, test, measuring and diagnostic equipment, which are stocked and supplied by the Army COMSEC Logistic System and which are not subject to the provisions of AR 380-41.
P10	Assigned to items which are NSA design controlled: special tools, test, measuring and diagnostic equipment for COMSEC support, which are accountable under the provisions of AR 380-41, and which are stocked and supplied by the Army COMSEC Logistic System.

<i>Code</i>	<i>Explanation</i>
M	Repair Parts, Special Tools and Test Equipment which are not procured or stocked, as such, in the supply system but are to be manufactured at indicated maintenance levels.
A	Assemblies which are not procured or stocked as such, but are made up of two or more units. Such component units carry individual stock numbers and descriptions, are procured and stocked separately and can be assembled to form the required assembly at indicated maintenance categories.
X	Parts and assemblies that are not procured or stocked because the failure rate is normally below that of the applicable end item of component. The failure of such part or assembly should result in retirement of the end item from the supply system.
X1	Repair Parts which are not procured or stocked. The requirement for such items will be filled by the next higher assembly or component.
X2	Repair Parts, Special Tools, and Test Equipment which are not stocked and have no foreseen mortality. The indicated maintenance category requiring such repair parts will attempt to obtain the parts through cannibalization or salvage, if not obtainable through cannibalization or salvage, the item may be requisitioned with exception data, from the end item manager, for immediate use.
G	Major assemblies that are procured with PEMA funds for initial issue only as exchange assemblies at DSU and GSU level. These assemblies will not he stocked above the DS and GS level or returned to depot supply level.

#### NOTE

Cannibalization or salvage may be used as a source of supply for any items source coded above, except those coded X1.

(2) Maintenance Code, indicates the lowest category of maintenance authorized to install the listed item. The maintenance level codes are—

<i>Code</i>	<i>Explanation</i>
C	Crew of Operator Maintenance
O	Organization Maintenance
F	Direct Support Maintenance
H	General Support Maintenance
D	Depot Maintenance

(3) Recoverability Code, indicates whether unserviceable items should be returned for recovery or salvage. Recoverability Codes are—

<i>Code</i>	<i>Explanation</i>
R	Applied to repair parts, (assemblies and components) special tools and test equipment which are

Code

Explanation

considered economically repairable at Direct and General Support Maintenance levels. When the item is no longer economically repairable, it is normally disposed of at the GS level. When supply considerations dictate, some of these repair parts may be listed for automatic return to supply for depot level repair as set forth in AR 710-50. When so listed, they will be replaced by supply on an exchange basis.

S Repair Parts, Special Tools, Test Equipment and assemblies which are economically repairable at DSU and GSU activities and which normally are furnished by supply on an exchange basis. When items are determined by a GSU to be uneconomically repairable, they will be evacuated to a depot for evaluation and analysis before final disposition.

T Higher dollar value recoverable repair parts, special tools, and test equipment which are subject to special handling and are issued on an exchange basis. Such items will be evacuated to the depot for overhaul or final disposition. Communications-Electronics and Missile Support, Items will be repaired / overhauled only at depots.

U Repair Parts, Special Tools and Test Equipment specifically selected for salvage by reclamation units because of precious metal content, critical materials, high dollar value or reusable casings or castings.

NOTE

When no code is indicated in the recoverability column, the part will be considered non-recoverable.

b. Federal Stock Number (FSN), Column 2. This column indicates the Federal stock number assigned to the item and will be used for requisitioning purposes.

c. Description, Column 3. This column indicates the Federal item name and any additional description of the item required. A part number or other reference number is followed by the applicable five-digit Federal supply code for manufacturers in parentheses. Repair parts quantities included in the kits, sets, and assemblies are shown in front of the repair part name.

d. Unit of Measure U/M, Column 4. A 2 character alphabetic abbreviation indicating the amount or quantity of the item upon which the allowances are based, e.g., ft., ea., pr., etc.

e. Quantity Incorporated in Unit, Column 5. This column indicates the quantity of the item used in the assembly group. A "V" appearing in this column in lieu of a quantity indicates that a definite quantity cannot be specified (e.g., shims, spacers, etc.)

f. 30-Day DS/ GS Maintenance Authorization, Columns 6, and 7.

(1) The Repair Parts List includes asterisk entries in separate columns—one for Direct Support (DS) and one for General Support (GS)—as appropriate to indicate the total range of repair parts authorized for use at that category or required to be removed or disassembled during the performance of authorized maintenance operations. They will be requisitioned initially on an "as required" basis. The repair parts authorized at the DS / GS levels will be those authorized for the maintenance mission at these levels. Requirements for repair part stockage and for distribution to supported units will be based on demand and determined in accordance with AR 710-2.

(2) Special Tools or Test, Measurement and Diagnostic Equipment (TMDE) and other support equipment peculiar to an item are listed with quantities in the appropriate density spread / allowance columns. (Not applicable to this manual).

g. 1-Year Allowances Per 100 Equipments / Contingency Planning Purposes, Column 8. This column indicates the requirement for contingency planning purposes. An asterisk indicates authorization to obtain or use as required.

h. Depot Maintenance Allowances Per 100 Equipments, Column 9. This column indicates authorization for depot use.

i. Illustration, Column 10. This column is divided as follows:

(1) Figure Number, Column 10a. Indicates the figure number of the illustration in which the item is shown.

(2) Item Number, Column 10b. Indicates the callout number used to reference the items in the illustration.

4. Special Information

a. End item application:

Vehicle

TM No.

Chassis, Truck: 2½-Ton, 1/2-Ton, 6 x 6, M44, M44A1, M44A2, M45, M45C, M45A1, M45A2, M45A2G

9-2320-209-10,20,35

Chassis, Truck: 2½-Ton, 1/2-Ton, 6 x 6, M133, M207, M207C

9-8024

Truck, Cargo: 2½-Ton, 1/2-Ton, 6 x 6, M34, M35, M35A1, M35A2, M35A2C, M36, M36C, M36A2

9-2320-209-10,20,35

Truck, Cargo: 6 x 6, M135, M211

9-8024

Truck Dump: 2½-Ton, 1/2-Ton, 6 x 6, M47, M59, M342, M342A2

9-2320-209-10,20,35

Truck Dump: 2½-Ton, 1/2-Ton, 6 x 6, M215

9-8024

Truck, Maintenance: Earth Boring Machine and Pole-Setter, 2½-Ton, 6 x 6, V-18A / MTQ, M764	
Truck, Maintenance: Telephone Construction 2½-Ton, 6 x 6, V17A / MTQ	
Truck, Tank: Fuel Servicing, 2½-Ton, 6 x 6, M49, M49C, M49A1C, M49A2C	9-2320-209-10,20,35
Truck, Pipeline Construction: 2½-Ton, 6 x 6, M756A2	
Truck, Tank: Water 2½-Ton, 6 x 6, 1,000 gal., M50 M50A1, M50A2	
Truck, Tractor: 2½-Ton, 6 x 6, M48, M275, M275A1, M275A2	
Truck, Tractor: 2½-Ton, 6 x 6, M221	9-8024
Truck, Van: Shop, 2½-Ton, 6 x 6, M109, M109A1, M109A2, M109A3	
Truck, Wrecker: Crane, 2½-Ton, 6 x 6, M108	9-2320-209-10,20,35
Truck, Wrecker: light, 2½-Ton, 6 x 6, M60	

b. Items listed for the front winch are applicable to (Model CA-514 only).

c. Items listed for the rear winches are applicable to vehicles as indicated unless otherwise indicated. Winch Assembly, for vehicle V18A / MTQ, is not an item of issue; however,

repair parts ,may be obtained by requisitioning those items shown with the applicable usable on code.

d. Identification of the usable on codes included in column 3 of this publication are:

Code	Description
A	Front winch FSN 2590-753-8687(7538687) figures 1 thru 4.
B	Rear winch FSN 2520-040-2112(8329808) figures 5 thru 8.
C	Rear winch FSN 2590-402-5200(11623130) figures 9 thru 17.

Code	Used on
A	Chassis, Truck: 2½-Ton, 6 x 6, M44, M44A1, M44A2, M45, M45C, M45A1, M45A2, M45A2G
	Chassis, Truck: 2½-Ton, 6 x 6, M133, M207, M207C
	Truck, Cargo: 2½-Ton, 6 x 6, M34, M35, M35A1, M35A2, M35A2C, M36, M36C, M36A2
	Truck, Cargo: 2½-Ton, 6 x 6, M135, M211
	Truck, Dump: 2½-Ton, 6 x 6, M47, M59, M342, M342A2
	Truck, Dump: 2½-Ton, 6 x 6, M215
	Truck, Maintenance: Earth Boring Machine and Pole Setter, 2½-Ton, 6 x 6, V-18A / MTQ, M764
	Truck, Maintenance: Telephone Construction, 2½-Ton, 6 x 6, V17A / MTQ
	Truck, Tank: Fuel Servicing, 2½-Ton, 6 x 6, M49, M49C, M49A1C, M49A2C
	Truck, Pipeline Construction: 2½-Ton, 6 x 6, M756A2
	Truck, Tank: Water, 2½-Ton, 6 x 6, 1,000 gal., M50, M50A1, M50A2
	Truck, Tractor: 2½-Ton, 6 x 6, M48, M275, M275A1, M275A2
	Truck, Tractor: 2½-Ton, 6 x 6, M221
	Truck, Van: Shop, 2½-Ton, 6 x 6, M109, M109A1, M109A2, M109A3
	Truck, Wrecker: crane, 2½-Ton, 6 x 6, M108
	Truck, Wrecker: light, 2½-Ton, 6 x 6, M60
B	Truck, Maintenance: Telephone Construction 2½-Ton, 6 x 6, V17A / MTQ
C	Truck, Maintenance: Earth Boring Machine and Pole-Setter, 2½-Ton, 6 x 6, V18A / MTQ, M764

determine the functional group or functional subgroup, i.e. engine, engine assembly transmission transmission assembly, within which the repair part belongs. This is necessary since illustrations are prepared for functional groups or functional subgroups and listings are divided into the same groups.

(2) Second. Find the illustration covering the functional group, functional subgroup to which the repair part belongs.

(3) 'Z'bird. Identify the repair part on the illustration and note the illustration figure and item number of the repair part.

(4) Fourth. Using the Repair Parts Listing, find the functional group, functional subgroup, to which the repair part belongs and locate the illustration figure and item number noted on the illustration.

b. When Federal stock number or reference number is known:

(1) First. Using the Index of Federal Stock Numbers and Reference Numbers find the pertinent Federal stock number or reference number. This index is in ascending FSN sequence followed by a list of reference numbers in alpha-numeric sequence, cross-referenced to the illustration figure number and item number.

(2) Second. Using the Repair Parts Listing, find the functional group or functional subgroup of the repair part and illustration figure number and item number referenced in the Index of Federal Stock Numbers and Reference Numbers.

## 5. How to Locate Repair Parts

a. When Federal stock number or reference number is unknown:

(1) First. Using the table of contents,

6. Abbreviation  
Not applicable.

## 7. Federal Supply Codes for Manufacturers

<i>Code</i>	<i>Manufacturer</i>
05869	Hughes Aircraft Co. Ground Systems Group P.O. Box 3310, Fullerton Calif., 92634
12204	Chrysler Corp. 341 Massachusetts Ave., Detroit, Mich., 48231
13190	Tridea Electronics A subsidiary of Conductron Corp. 11581 Federal Drive, El Monte Calif., 91731
19207	Army Tank-Automotive Command Warren, Mich., 48090
21450	Ordnance Corp. Engineering Standard Rock Island Arsenal Rock Island, Ill.
24076	Garwood Industries, Inc. 32500 Van Born Road Wayne Mich., 48186
24617	General Motors Corp. 3044 Grand Blvd. W. Detroit, Mich., 48202
50513	White Motor Co. Lansing, Mich.
64104	Waukesha Motor Co. P. O. Box 379 Waukesha Wis., 53187
73362	McCabe Powers Body Co. 8900 Frost Ave., St. Louis, Mo., 63134
74340	Highway Trailer Co. 405 E. Fulton St., Edgerton Wis., 53534
77667	Ramsey Products Corp. P. O. Box 8496 Charlotte, N. C., 28208
79150	Dana Corp. Victor Division P. O. Box 1333, Chicago, Ill., 60690

<i>Code</i>	<i>Manufacturer</i>
80201	Chicago Rawhide 1301 Elston Ave., Chicago, Ill., 60622
80244	General Services Administration Federal Supply Service Washington D. C., 20406
81348	Federal Specifications Promulgated by General Services Administration
88044	Aeronautical Standards group Dept. of Navy and Air Force Silver Springs, Md.
92679	International Harvester Co. 10400 W. North Ave., Melrose Park, Ill., 60160
96906	Military Standards Promulgated by Standardization Div. Directorate of Logistic Services DSA
97297	Armstrong Products Corp P. O. Box 940 Huntington, W, Va., 25712

## 8. Report of Equipment Publication Improvements

The reporting of errors, omissions, and recommendations for improving this publication by the individual user is encouraged. Reports should be submitted on DA Form 2028 (Recommended Changes to Publications) and forwarded direct to Commanding General, Headquarters U. S. Army Tank-Automotive Command ATTN: AMSTA-MAP, Warren, Mich., 48090.



## SECTION II

## REPAIR PARTS LIST

(1) SMR Code	(2) Federal Stock Number	(3) DESCRIPTION	(4) UNIT of meas	(5) Qty inc. in Unit	(6) 30-day DS maint allowance	(7) 30-day GS maint allowance	(8) 1-yr alw per 100 equip cnt- gcy	(9) Depot alw per 100 equip No.	(10) Illustration No. (a) Figure (b) Item				
Reference Number & Mfr. Code			Usable On Code	(a) 1-20	(b) 21-50	(c) 51-100	(a) 1-20	(b) 21-50	(c) 51-100				
GROUP 20-WINCH													
2001-WINCH ASSEMBLY													
P-F-R	2590-753-8687	WINCH,DRUM,VEHICLE: FRONT ASSEMBLY (ITEMS LISTED BELOW ARE APPLICABLE TO FRONT WINCH ONLY UNLESS OTHERWISE INDICATED BY USABLE ON CODES INCLUDED IN SECTION I PARAGRAPH 4D) 7538687 (19207)	A	EA	1	*	*	*	*	*	*	1	
P-H	2590-857-2750	CHANNEL: WINCH ASSEMBLY 7529101 (19207)		EA	1		*	*	*	*	*	2	1
P-H	5305-782-9495	SCREW,CAP,HEXAGON: CHANNEL MS90725-111(96906)		EA	1		*	*	*	*	*	2	2
P-H	5310-584-5272	WASHER,LOCK: CHANNEL (4) RETAINING PLATE (10) MS35338-48 (96906)		EA	1		*	*	*	*	*	2	3
P-O	4730-278-3357	PLUG,PIPE: OIL FILLER, DRAIN AND LEVEL 103881 (92679)		EA	2	*	*	*	*	*	*	2	4
P-O	5305-715-1194	SETScrew: OIL FILLER AND DRAIN MS51981-80 (96906)		EA	2	*	*	*	*	*	*	2	5
P-H	3110-144-8669	BEARING, BALL, ANNULAR: WORM SHAFT 700338 (21450)		EA	2		*	*	*	*	*	2	6
P-H	5330-753-8728	GASKET: WORM SHAFT AUTOMATIC BRAKE CASE 7538728 (19207)		EA	2		*	*	*	*	*	2	7
P-H	5330-695-1170	SEAL,PLAIN,ENCASED: OIL, WORM SHAFT BEARING 7538704 (19207)		EA	1		*	*	*	*	*	2	8
P-H	3830-753-8732	PLATE,RETAINING,SHAFT: WORM SHAFT BEARING 7538732 (19207)		EA	1		*	*	*	*	*	2	9
P-H	5305-782-9494	SCREW,CAP,HEXAGON: AUTOMATIC BRAKE CASE MS90725-114 (96906)		EA	10		*	*	*	*	*	2	10
P2-H	2520-741-2651	COVER ASSEMBLY, GEAR CASE: WINCH ASSEMBLY 7412651 (19207)		EA	1		*	*	*	*	*	2	11
P-H	3120-753-8696	BEARING,SLEEVE: GEAR CASE (1) COVER (1) 7538696 (19207)		EA	2		*	*	*	*	*	2	12
P-H	5330-753-8737	GASKET: GEAR COVER 7538737 (19207)		EA	1		*	*	*	*	*	2	13
P-H	2540-753-8698	COVER: GEAR CASE 7538698 (19207)		EA	1		*	*	*	*	*	2	14
P-H	5306-109-4403	BOLT,SHOULDER: GEAR CASE COVER 7538710 (19207)		EA	8		*	*	*	*	*	2	15

(1) SMR Code	(2) Federal Stock Number	(3) DESCRIPTION	(4) UNIT of meas	(5) Qty inc. in Unit	(6) 30-day DS maint allowance			(7) 30-day GS maint allowance			(8) 1-yr alw per 100 equip cnt- gcy	(9) Depot maint alw per 100 equip	(10) Illustration	
					(a) 1-20	(b) 21-50	(c) 51-100	(a) 1-20	(b) 21-50	(c) 51-100			(a) Figure No.	(b) Item No.
		Reference Number & Mfr. Code												
		Usable On Code												
		2001-WINCH ASSEMBLY-CONTINUED												
P-H	5310-167-0680	WASHER,LOCK:GEAR CASE COVER MS35338-49 (96906)	EA	8				*	*	*	*	*	2	16
P-H	5315-736-8685	PIN,STRAIGHT,HEADLESS: DRIVE SHAFT TO END YOKE 7368685 (19207)	EA	1				*	*	*	*	*	2	17
P-H	5315-753-8333	PIN, COTTER: DRIVE SHAFT SHEAR PIN MS24665-145 (96906)	EA	2				*	*	*	*	*	2	18
P-H	2520-741-2745	WORM ASSEMBLY WINCH: AUTOMATIC GEAR CASE 7412745 (19207)	EA	1				*	*	*	*	*	2	19
P-H	2540-753-8707	WORM: GEAR 7538707 (19207)	EA	1				*	*	*	*	*	2	20
P-H	5315-616-5522	KEY,WOODRUFF: WORM ASSEMBLY 106751 (50513)	EA	1				*	*	*	*	*	2	21
P-H	5330-286-8149	SEAL,PLAIN ENCASED: WORM SHAFT BEARING 500094 (24617)	EA	1				*	*	*	*	*	2	22
P-F	5340-050-1589	PLUG,EXPANSION: AUTOMATIC BRAKE MS35648-3 (96906)	EA	1	*	*	*	*	*	*	*	*	2	23
P-F	2590-318-4299	GASKET: AUTOMATIC BRAKE CASE 8333643 (19207)	EA	1	*	*	*	*	*	*	*	*	2	24
P-F	2590-753-8892	BRAKE DRUM: AUTOMATIC BRAKE 7538892 (19207)	EA	1	*	*	*	*	*	*	*	*	2	25
P-F	3830-625-4418	BRAKE BAND ASSEMBLY: AUTOMATIC BRAKE WITH LINING 7538731 (19207)	EA	1	*	*	*	*	*	*	*	*	2	26
P-F	2530-753-8730	LINING,FRICTION: (COMPONENT OF LINING KIT, FSN 2530-741-2654) 2286151 (24617)	EA	1	*	*	*	*	*	*	*	*	2	27
X1		BAND ASSEMBLY: AUTOMATIC BRAKE 8690290 (19207)		1									2	28
P-F	5320-012-1573	RIVET: LINING TO BAND (COMPONENT OF LINING KIT, FSN 2530-741-2654) 121573 (24617)	EA	10	*	*	*	*	*	*	*	*	2	29
P-F	3830-699-6379	SPRING,WINCH BRAKE: ADJUSTING BRAKE BOLT 2208436 (24617)	EA	1	*	*	*	*	*	*	*	*	2	30
P-F	2590-753-8701	COVER,ACCESS: AUTOMATIC BRAKE CASE 7538701 (19207)	EA	1	*	*	*	*	*	*	*	*	2	31
P-F	5306-018-7527	BOLT,ASSEMBLED WASHER: ACCESS COVER 187527 (50513)	EA	6	*	*	*	*	*	*	*	*	2	32
P-F	5306-012-0741	SCREW: BRAKE DISK 120741 (50513)	EA	1	*	*	*	*	*	*	*	*	2	33
P-F	5310-407-9566	WASHER,LOCK:BRAKE DISK MS35338-45 (96906)	EA	1	*	*	*	*	*	*	*	*	2	34

(1) SMR Code	(2) Federal Stock Number	(3) DESCRIPTION	(4) UNIT of meas	(5) Qty inc. in Unit	(6) 30-day DS maint allowance			(7) 30-day GS maint allowance			(8) 1-yr alw per 100 equip cnt- gcy	(9) Depot maint alw per 100 equip	(10) Illustration	
Reference Number & Mfr. Code			Usable On Code		(a)	(b)	(c)	(a)	(b)	(c)		(a)	(b)	
					1-20	21-50	51-100	1-20	21-50	51-100		100 equip No.	100 equip No.	
		2001-WINCH ASSEMBLY-CONTINUED												
P-F	5310-527-7972	WASHER,FLAT: BRAKE DISK 5277972 (19207)	EA	1	*	*	*	*	*	*	*	*	2	35
P-F	5305-012-6167	SCREW: AUTOMATIC BRAKE CASE 126167 (50513)	EA	1	*	*	*	*	*	*	*	*	2	36
P-F	5995-999-4375	WASHER: AUTOMATIC BRAKE CASE 120394 (13190)	EA	1	*	*	*	*	*	*	*	*	2	37
P-F	5330-640-9613	PACKING,PREFORMED: AUTOMATIC BRAKE CASE AN6227-7 (88044)	EA	1	*	*	*	*	*	*	*	*	2	38
P-F	2540-753-8697	CASE: AUTOMATIC BRAKE 7538697 (19207)	EA	1	*	*	*	*	*	*	*	*	2	39
P-F	5310-045-1081	NUT,SELF-LOCKING,HEXAGON: GUIDE LINE ROD 451081 (21450)	EA	3	*	*	*	*	*	*	*	*	2	40
P-O		BOLT: GEAR CASE ASSEMBLY 133870 (21450)	EA	4	*	*	*	*	*	*	*	*	2	41
P-F	5306-753-8735	ROD,THREADED END : GUID LINE 2286134 (24617)	EA	1	*	*	*	*	*	*	*	*	2	42
P-H	3830-752-9102	GEAR CASE ASEMBLY,WINCH: WITH BEARING 7529102 (19207)	EA	1				*	*	*	*	*	2	43
P-H	2540-753-8699	CASE,ASSEMBLY: 7538699 (19207)	EA	1				*	*	*	*	*	2	44
P-O	5310-880-7744	NUT,PLAIN,HEXAGON: LOCK POPPET LATCH MS51967-5 (96906)	EA	3	*	*	*	*	*	*	*	*	3	1
P-O	2540-740-9150	LATCH DRUM POPPET: FRONT WINCH ASEMBLY 7409150 (19207)	EA	1	*	*	*	*	*	*	*	*	3	2
P-O	5306-753-8725	BOLT,INTERNALLY RELEASE: DRUM LOCK PLUNGER 7538725 (19207)	EA	1	*	*	*	*	*	*	*	*	3	3
P-O	2590-753-8706	SPRING,HELICAL: COMPRESSION: DRUM LOCKING PLUNGER 7538706 (19207)	EA	1	*	*	*	*	*	*	*	*	3	4
P-F	5315-696-0789	PIN,SHOULDERD,HEADLESS: LOCKING DRUM CABLE 8723828 (19207)	EA	1	*	*	*	*	*	*	*	*	3	5
P-O	4730-018-9566	PLUG,PIPE: END PLATE (1) DRUM ASSEMBLY (1) G1251 (24617)	EA	2	*	*	*	*	*	*	*	*	3	6
P-F		BOLT: END PLATE 139747 (21450)	EA	1	*	*	*	*	*	*	*	*	3	7
P-O	4730-278-3357	PLUG,PIPE: OIL FILTER, DRAIN AND LEVEL 103881 (92679)	EA	2	*	*	*	*	*	*	*	*	3	8
P-F	5305-715-1194	SET SCREW: DRUM ASSEMBLY MS51981-80 (96906)	EA	1	*	*	*	*	*	*	*	*	3	9
P-H	5330-291-1554	SEAL,PLAIN ENCASED: OIL, CLUTCH SHIFTING YOKE SHAFT 7538695 (19207)	EA	1				*	*	*	*	*	3	10

(1) SMR Code	(2) Federal Stock Number	(3) DESCRIPTION	(4) UNIT of meas	(5) Qty inc. in Unit	(6) 30-day DS maint allowance			(7) 30-day GS maint allowance			(8) 1-yr alw per 100 equip cnt- gcy	(9) Depot maint alw per 100 equip	(10) Illustration	
					(a) 1-20	(b) 21-50	(c) 51-100	(a) 1-20	(b) 21-50	(c) 51-100			(a) Figure No.	(b) Item No.
		Reference Number & Mfr. Code												
		Usable On Code												
		2001-WINCH ASSEMBLY-CONTINUED												
P-H	2540-753-8729	PLATE: CLUTCH CONTROL LEVER 7538729 (19207)	EA	1				*	*	*	*	*	3	11
P-H	5310-820-6653	WASHER, LOCK: BOLT, CLUTCH PLATE MS35338-50 (96906)	EA	7				*	*	*	*	*	3	12
P-H	5305-044-5503	BOLT: CLUTCH PLATE CONTROL MS90725-160 (96906)	EA	1				*	*	*	*	*	3	13
P-H	5315-616-5523	KEY, WOODRUFF: SHAFT SHIFTER MS35756-11 (96906)	EA	2				*	*	*	*	*	3	14
P-H	2590-753-8734	SHAFT, STRAIGHT: SHIFTER, DRUM SLIDING CLUTCH 7538734 (19207)	EA	1				*	*	*	*	*	3	15
P-F	2540-753-8708	LEVER: CLUTCH CONTROL 7538708 (19207)	EA	1	*	*	*	*	*	*	*	*	3	16
P-F	5310-407-9566	WASHER, LOCK: LEVER CONTROL MS35338-45 (96906)	EA	1	*	*	*	*	*	*	*	*	3	17
P-F	5306-225-9081	BOLT, MACHINE: LEVEL CONTROL MS90725-36 (96906)	EA	1	*	*	*	*	*	*	*	*	3	18
P-F	2590-740-9727	SPRING, HELICAL, COMPRESSION: CLUTCH SHIFTER 7538722 (192007)	EA	1	*	*	*	*	*	*	*	*	3	19
P-H	3110-948-9796	BALL, BEARING: SHIFTING YOKE MS19061-13 (96906)	EA	1				*	*	*	*	*	3	20
X2-H		CHANNEL: WINCH ASSEMBLY 7529100 (19207)	EA	1				*	*	*	*	*	3	21
P-H	5330-696-0279	SEAL, PLAIN, ENCASED: END FRAME 7538694 (19207)	EA	1				*	*	*	*	*	3	22
P-H	3120-753-8711	BEARING: END FRAME 7538711 (19207)	EA	1				*	*	*	*	*	3	23
P-H	3120-753-8696	BEARING, SLEEVE: END PLATE (1) DRUM ASSEMBLY (1) WORM GEAR (1) 7538696 (19207)	EA	3				*	*	*	*	*	3	24
P-H	2540-753-8702	RING: CABLE DRUM SHAFT 7538702 (19207)	EA	1				*	*	*	*	*	3	25
P-H	2520-695-3350	YOKE, SHIFTER CLUTCH: DRUM ASSEMBLY 2286160 (24617)	EA	1				*	*	*	*	*	3	26
P-H	5305-012-5843	SCREW: YOKE SHIFTER 125843 (24617)	EA	1				*	*	*	*	*	3	27
P-H	2520-741-2652	DRUM ASSEMBLY WINCH: FRONT WINCH ASSEMBLY 7412652 (19207)	EA	1				*	*	*	*	*	3	28
P-H	2540-753-8690	DRUM ASSEMBLY: FRONT WINCH ASSEMBLY 7538690 (19207)	EA	1				*	*	*	*	*	3	29
P-H	5330-179-0972	SEAL, PLAIN, ENCASED: DRUM ASSEMBLY 500261 (19207)	EA	1				*	*	*	*	*	3	30

(1) SMR Code	(2) Federal Stock Number	(3) DESCRIPTION	(4) UNIT of meas	(5) Qty inc. in Unit	(6) 30-day DS maint allowance			(7) 30-day GS maint allowance			(8) 1-yr alw per 100 equip cnt- gcy	(9) Depot maint alw per 100 equip	(10) Illustration	
					(a) 1-20	(b) 21-50	(c) 51-100	(a) 1-20	(b) 21-50	(c) 51-100			(a) Figure No.	(b) Item No.
		Reference Number & Mfr. Code												
		2001-WINCH ASSEMBLY-CONTINUED												
P-H	2590-753-8703	WASHER,THRUST: CABLE DRUM SHAFT 2286131 (24617)	EA	1				*	*	*	*	*	3	31
P-H		KEY,MACHINE: DRUM SHAFT 8330519 (19207)	EA	2				*	*	*	*	*	3	32
P-H	2520-741-2656	SHAFT ASSEMBLY DRUM: FRONT WINCH ASSEMBLY 7412656 (19207)	EA	1				*	*	*	*	*	3	33
P-H	5315-281-7651	KEY,MACHINE: DRUM SHAFT 8328341 (19207)	EA	2				*	*	*	*	*	3	34
P-H	2590-262-7572	GEAR,WORM WHEEL: WORM DRIVEN 7538688 (19207)	EA	1				*	*	*	*	*	3	35
P-H	5305-725-0166	SET SCREW: MS51963-138 (96906)	EA	1				*	*	*	*	*	3	36
P-H	2520-695-3342	CLUTCH,SLIDING DRUM: FRONT WINCH ASSEMBLY 7538691 (19207)	EA	1				*	*	*	*	*	3	37
P-H	2540-753-8726	BRAKE; DRAG, DRUM ASSEMBLY 7538726 (19207)	EA	1				*	*	*	*	*	3	38
P-H	5320-264-3169	RIVET,TUBULAR: 104945 (21450)	EA	2				*	*	*	*	*	3	39
P-H	2590-753-8727	LINING,FRICTION: 7538727 (19207)	EA	1				*	*	*	*	*	3	40
X1		SHOE ASSEMBLY: 7954459 (19207)		1									3	41
P-H	5340-573-3334	SPRING,HELICAL,COMPRESSION: DRAG BRAKE 305580 (24076)	EA	1				*	*	*	*	*	3	42
P-H	5315-014-1240	PIN,STRAIGHT HEADLESS: BRAKE DRUM 141240 (50513)	EA	1				*	*	*	*	*	3	43
P-H	2540-753-8700	FRAME: END PLATE ASSEMBLY 7538700 (19207)	EA	1				*	*	*	*	*	3	44
P-H		SCREW: END PLATE 139194 (21450)	EA	1				*	*	*	*	*	3	45
P-O	5305-873-6946	SET SCREW: ADJUSTING CABLE DRUM BRAKE 7538733 (19207)	EA	1	*	*	*	*	*	*	*	*	3	46
P-O	2590-179-3442	SPACER,WINCH:END PLATE ASSEMBLY 8710655 (19207)	EA	6	*	*	*	*	*	*	*	*	3	47
P-O	5310-933-8123	WASHER,LOCK: SHOULDER BOLT MS35339-30 (96906)	EA	6	*	*	*	*	*	*	*	*	3	48
P-O	5306-753-8709	BOLT,SHOULDER: WINCH MOUNTING 7538709 (19207)	EA	6	*	*	*	*	*	*	*	*	3	49
P-H	5340-054-1402	PLUG EXPANSION: END FRAME 541402 (21450)	EA	1				*	*	*	*	*	3	50

(1) SMR Code	(2) Federal Stock Number	(3) DESCRIPTION	(4) UNIT of meas	(5) Qty inc. in Unit	(6) 30-day DS maint allowance	(7) 30-day GS maint allowance	(8) 1-yr alw per 100 equip cnt- gcy	(9) Depot maint alw per 100 equip	(10) Illustration No.	(a) Figure No.	(b) Item No.			
Reference Number & Mfr. Code			Usable On Code			(a) 1-20	(b) 21-50	(c) 51-100	(a) 1-20	(b) 21-50	(c) 51-100			
		2001-WINCH ASSEMBLY-CONTINUED												
P-O	4010-508-4700	WIRE ROPE:	EA	1									4	1
		FABRICATE FROM:												
P-O	4010-274-6816	WIRE ROPE,STEEL: (200 FT.) 22R1365 (19207)	FT	V	*	*	*	*	*	*	*	*	4	2
P-O	4030-262-3152	CLEVIS: WIRE ROPE TO CHAIN ASSEMBLY 7071882 (19207)	EA	1	*	*	*	*	*	*	*	*	4	3
P-O	2540-368-5015	CHAIN ASSEMBLY SINGLE: (4 FT.) 7717030 (19207)	FT	V	*	*	*	*	*	*	*	*	4	4
P-O	4010-149-5619	LINK CHAIN,CONNECTION: RRC271 (81348)	EA	1	*	*	*	*	*	*	*	*	4	5
P-O	4010-286-5646	CHAIN,WELDED: CLASS 2 (81348)	FT	V	*	*	*	*	*	*	*	*	4	6
P-O	4010-337-8278	LINK,CHAIN END: 7717007 (19207)	EA	1	*	*	*	*	*	*	*	*	4	7
P-O	4030-274-3464	HOOK,HOIST: RRC271TYPECCCLASSD (31348)	EA	1	*	*	*	*	*	*	*	*	4	8
P-O	4030-266-0066	THIMBLE,ROPE: 507402 (21450)	EA	1	*	*	*	*	*	*	*	*	4	9
P-F-R	2520-040-2112	WINCH ASSEMBLY: REAR,WITH PILLOW BLOCK AND AUXILIARY SHAFT (ITEMS LISTED BELOW ARE APPLICABLE TO REAR WINCHES ONLY,UNLESS OTHERWISE INDICATED BY USABLE ON CODES INCLUDED IN SECTION I, PARAGRAPH 4D). 8329808 (19207)	B	EA	1	*	*	*	*	*	*	*	5	
P-O		BLOCK ASSEMBLY: PILLOW BLOCK 190A23 (74340)	EA	1	*	*	*	*	*	*	*	*	6	1
P-F	5310-115-6869	PIN: PILLOW BLOCK 103387 (21450)	EA	2	*	*	*	*	*	*	*	*	6	2
P-F	5305-417-6579	NUT: PILLOW BLOCK HG11067 (74340)	EA	2	*	*	*	*	*	*	*	*	6	3
X1		WASHER: PILLOW BLOCK HG105E11 (74340)		2									6	4
X1		SPROCKET: PILLOW BLOCK 8329805 (19207)		1									6	5
P-F	5330-286-7059	SEAL PLAIN ENCASED: PILLOW BLOCK 31324 (80201)	EA	2	*	*	*	*	*	*	*	*	6	6
P-F	5305-042-6953	SCREW CAP,HEXAGON: PILLOW BLOCK 426953 (21450)	EA	2	*	*	*	*	*	*	*	*	6	7
X1		RETAINER: PILLOW BLOCK HG119E98 (74340)		2									6	8
X1		SHIM: PILLOW BLOCK 142E44 (74340)		2									6	9

(1) SMR Code	(2) Federal Stock Number	(3) DESCRIPTION	(4) UNIT of meas	(5) Qty inc. in Unit	(6) 30-day DS maint allowance			(7) 30-day GS maint allowance			(8) 1-yr alw per 100 equip cnt- gcy	(9) Depot maint alw per 100 equip	(10) Illustration No. (a) (b) Figure Item No. No.	
		Reference Number & Mfr. Code	Usable On Code		(a) 1-20	(b) 21-50	(c) 51-100	(a) 1-20	(b) 21-50	(c) 51-100				
		2001-WINCH ASSEMBLY-CONTINUED												
P-F	3110-100-0800	CUP,TAPERED ROLLER: PILLOW BLOCK 707067 (21450)	EA	2	*	*	*	*	*	*	*	*	*	6 10
P-F	3110-100-0208	CONE AND ROLLER,TAPERED: PILLOW BLOCK 705023 (21450)	EA	2	*	*	*	*	*	*	*	*	*	6 11
X1		BOLT: PILLOW BLOCK HG142B62 (74340)		1										6 12
P-F	5310-021-9710	NUT,PLAIN,HEXAGON: PILLOW BLOCK 219710 (21450)	EA	1	*	*	*	*	*	*	*	*	*	6 13
X1		HOUSING: PILLOW BLOCK HG190A22 (74340)		1										6 14
P-F	6130-896-1829	KEY: PILLOW BLOCK 542695 (05869)		1	*	*	*	*	*	*	*	*	*	6 15
X1		SHAFT: PILLOW BLOCK HG285B60 (74340)		1										6 16
P-F	2590-040-2126	FLANGE: PILLOW BOLCK 8329866 (19207)	EA	1	*	*	*	*	*	*	*	*	*	6 17
P-O	4730-050-4208	FITTING: PILLOW BLOCK (1) AUXILIARY BRACKET (2) MS15003-1 (96906)	EA	3	*	*	*	*	*	*	*	*	*	6 18
P-O	2520-032-2896	CHAIN, SILENT: WINCH SPROCKET TO PILLOW BLOCK SPROCKET 8329792 (19207)	EA	1	*	*	*	*	*	*	*	*	*	6 19
X2-F		BASE: PILLOW BLOCK TO WINCH HG-W2883B (74340)	EA	1	*	*	*	*	*	*	*	*	*	6 20
P-O	5310-584-5272	WASHER,LOCK: AUXILIARY BASE MS35338-48 (96906)	EA	8	*	*	*	*	*	*	*	*	*	6 21
P-O	5310-021-4267	NUT,PLAIN,HEXAGON: AUXILIARY BASE 214267 (21450)	EA	8	*	*	*	*	*	*	*	*	*	6 22
P-F	2540-040-2105	BRACKET: AUXILIARY SHAFT 8329780 (19207)	EA	2	*	*	*	*	*	*	*	*	*	6 23
P-F	3120-734-0526	BEARING: AUXILIARY SHAFT 607563 (24617)	EA	2	*	*	*	*	*	*	*	*	*	6 24
P-F	5315-054-5552	PIN,TAPERED,PLAIN; AUXILIARY SHAFT 221376 (21450)	EA	2	*	*	*	*	*	*	*	*	*	6 25
X2-F		SHIM: AUXILIARY BRACKET HG-W2885A (74340)	EA	V	*	*	*	*	*	*	*	*	*	6 26
X2-F		SPACER: AUXILIARY SHAFT HG31A587-2 (74340)	EA	V	*	*	*	*	*	*	*	*	*	6 27
P-O	2520-032-2895	CHAIN,SILENT: SPINDLE SPROCKET 8329791 (19207)	EA	1	*	*	*	*	*	*	*	*	*	6 28
X2-F		KEY: AUXILIARY SHAFT 7540181 (19207)	EA	1	*	*	*	*	*	*	*	*	*	6 29

(1) SMR Code	(2) Federal Stock Number	(3) DESCRIPTION	(4) UNIT of meas	(5) Qty inc. in Unit	(6) 30-day DS maint allowance	(7) 30-day GS maint allowance	(8) 1-yr alw per 100 equip cnt- gcy	(9) Depot maint alw per 100 equip	(10) Illustration alw per 100 equip	(a) Figure No.	(b) Item No.
Reference Number & Mfr. Code			Usable On Code			(a)	(b)	(c)	(a)	(b)	(c)
						1-20	21-50	51-100	1-20	21-50	51-100
		2001-WINCH ASSEMBLY-CONTINUED									
X2-F		PIN: AUXILIARY SHAFT HG110E27 (74340)	EA	1	*	*	*	*	*	*	6 30
X2-F		SHAFT: AUXILIARY SHAFT HF-W2878C (74340)	EA	1	*	*	*	*	*	*	6 31
X2-F		PIN: AUXILIARY SHAFT RMP-SC610LP (77667)	EA	1	*	*	*	*	*	*	6 32
P-F	5315-010-3362	PIN: AUXILIARY SHAFT 103362 (92679)	EA	1	*	*	*	*	*	*	6 33
X2-F		PIN: AUXILIARY SHAFT RMP-SC610SP (77667)	EA	1	*	*	*	*	*	*	6 34
P-F	2520-318-0928	SPROCKET: AUXILIARY SHAFT SPINDLE 8329806 (19207)	EA	1	*	*	*	*	*	*	6 35
P-F		SCREW: AUXILIARY BRACKET 139416 (21450)	EA	2	*	*	*	*	*	*	6 36
P-F	5305-226-7768	SCREW,CAP,HEXAGON: BRACKET ASSEMBLY MS90726-115 (96906)	EA	20	*	*	*	*	*	*	6 37
P-F	2590-770-1738	COLLAR,SHAFT: AUXILIARY SHAFT 7701738 (19207)	EA	2	*	*	*	*	*	*	6 38
P-F	5310-809-5997	WASHER,FLAT: AUXILIARY BRACKET MS27183-17 (96906)	EA	4	*	*	*	*	*	*	6 39
P-F	5315-282-0328	PIN,STRAIGHT,HEADED: GEAR FORK 8329798 (19207)	EA	2	*	*	*	*	*	*	7 1
P-F	5320-010-4091	RIVET: GEAR FORK 104091 (24617)	EA	1	*	*	*	*	*	*	7 2
X2-F		FORK: GEAR CASE HG239B67 (74340)	EA	1	*	*	*	*	*	*	7 3
P-F	5305-269-2803	SCREW,CAP,HEXAGON: GEAR BRACKET MS90726-60 (96906)	EA	1	*	*	*	*	*	*	7 4
P-F	5310-637-9541	WASHER,LOCK: GEAR FORK MS35338-46 (96906)	EA	1	*	*	*	*	*	*	7 5
X2-F		BRACKET: GEAR ASSEMBLY HG216A97 (74340)	EA	1	*	*	*	*	*	*	7 6
P-F	7310-999-2563	KEY: SHAFT 505761 (97297)	EA	1	*	*	*	*	*	*	7 7
P-F	3830-996-7394	SHAFT,STRAIGHT: FORK TO BRACKET 127S23 (74340)	EA	1	*	*	*	*	*	*	7 8
X2-F		COVER: GEAR CASE 7701745 (19207)	EA	1	*	*	*	*	*	*	7 9
P-F	2590-770-1753	GASKET: GEAR CASE 7701753 (19207)	EA	2	*	*	*	*	*	*	7 10



(1) SMR Code	(2) Federal Stock Number	(3) DESCRIPTION	(4) UNIT of meas	(5) Qty inc. in Unit	(6) 30-day DS maint allowance	(7) 30-day GS maint allowance	(8) 1-yr alw per 100 equip cnt- gcy	(9) Depot maint alw per 100 equip	(10) Illustration No. (a) Figure (b) Item No.				
Reference Number & Mfr. Code			Usable On Code			(a) 1-20	(b) 21-50	(c) 51-100	(a) 1-20	(b) 21-50	(c) 51-100		
		2001-WINCH ASSEMBLY-CONTINUED											
X2-F		HOUSING: GEAR CASE HG157A88 (74340)	EA	1	*	*	*	*	*	*	*		7 11
P-F	2590-770-1749	GASKET: GEAR CASE 7701749 (19207)	EA	2	*	*	*	*	*	*	*		7 12
P-F	2590-318-0930	WORM SHAFT: LEFT DRIVE 8329809 (74340)	EA	1	*	*	*	*	*	*	*		7 13
P-F	2540-770-1754	WORM SHAFT: RIGHT DRIVE 7701754 (19207)	EA	1	*	*	*	*	*	*	*		7 13
P-O		WIRE: GEAR CASE 22-W-1630 (80244)	FT	V	*	*	*	*	*	*	*		7 14
P-F		SCREW: GEAR RETAINER HG119E62 (74340)	EA	1	*	*	*	*	*	*	*		7 15
X2-F		RETAINER: WORM GEAR 7701026 (19207)	EA	1	*	*	*	*	*	*	*		7 16
P-F	3110-183-9872	BEARING,ROLLR,JOURNAL: WINCH WORM 16476 (24617)	EA	1	*	*	*	*	*	*	*		7 17
X2-F		CAGE: GEAR CASE HG176A34 (74340)	EA	1	*	*	*	*	*	*	*		7 18
P-F	5310-584-5272	WASHR,LOCK: CAGE MOUNTING MS35338-48 (96906)	EA	8	*	*	*	*	*	*	*		7 19
P-F	5305-725-4183	SCREW,CAP,HEXAGON: CAGE MOUNTING 120234 (21450)	EA	8	*	*	*	*	*	*	*		7 20
P-F	5330-286-7051	SEAL,PLAIN,ENCASED: GEAR CASE 500117 (21450)	EA	1	*	*	*	*	*	*	*		7 21
P-F	2540-770-1017	SLEEVE: GEAR WORM 7701017 (19207)	EA	1	*	*	*	*	*	*	*		7 22
P-F	5315-693-0216	PIN WORM SHAFT STOP: WORM GEAR 7367930 (19207)	EA	1	*	*	*	*	*	*	*		7 23
X2-F		KEY: WORM SHFAT 7540181 (19207)	EA	1	*	*	*	*	*	*	*		7 24
P-O	4730-221-2139	PLUG: GEAR CASE MS20913-4S (96906)	EA	1	*	*	*	*	*	*	*		7 25
P-F	5306-207-2436	BOLT,MACHINE: GEAR PLATE 7701752 (19207)	EA	4	*	*	*	*	*	*	*		7 26
P-F	2540-376-8205	PIN: GEAR PLATE 103373 (12204)	EA	1	*	*	*	*	*	*	*		7 27
P-F	2590-351-2847	PLATE,WINCH HOUSING: GEAR CASE 8329801 (19207)	EA	1	*	*	*	*	*	*	*		7 28
P-F	3830-770-1768	THIMBLE,AUTOMATIC: GEAR CASE 7701768 (19207)	EA	2	*	*	*	*	*	*	*		7 29

(1) SMR Code	(2) Federal Stock Number	(3) DESCRIPTION	(4) UNIT of meas	(5) Qty inc. in Unit	(6) 30-day DS maint allowance			(7) 30-day GS maint allowance			(8) 1-yr alw per 100 equip cnt- gcy	(9) Depot maint alw per 100 equip	(10) Illustration	
					(a) 1-20	(b) 21-50	(c) 51-100	(a) 1-20	(b) 21-50	(c) 51-100			(a) Figure No.	(b) Item No.
		Reference Number & Mfr. Code		Usable On Code										
P-F	2530-321-6384	2001-WINCH ASSEMBLY-CONTINUED SPRING,HELICAL,COMPRESSION: GEAR CASE 8329804 (19207)	EA	2	*	*	*	*	*	*	*	*	7	30
P-F	5305-995-4332	SCREW,MACHINE: AUTOMATIC BRAKE 110E11 (74340)	EA	2	*	*	*	*	*	*	*	*	7	31
P-F	5310-021-4267	NUT,PLAIN,HEXAGON: AUTOMATIC BRAKE 214267 (21450)	EA	2	*	*	*	*	*	*	*	*	7	32
P-F	2590-406-1507	PLATE,WINCH DRIVE: AUTOMATIC BRAKE 8329800 (19207)	EA	2	*	*	*	*	*	*	*	*	7	33
P-F	2530-318-0916	LINING: AUTOMATIC BRAKE 8328120 (19207)	EA	2	*	*	*	*	*	*	*	*	7	34
X2-F		PLATE: AUTOMATIC BRAKE 7735927 (19207)	EA	1	*	*	*	*	*	*			7	35
P-F	2540-770-1755	GASKET: AUTOMATIC BRAKE 7701755 (19207)	EA	1	*	*	*	*	*	*	*	*	7	36
P-F	5315-145-1873	PIN,STRAIGHT,HEADLESS: AUTOMATIC BRAKE 8329799 (19207)	EA	1	*	*	*	*	*	*	*	*	7	37
P-F	2540-040-2108	NUT ASSEMBLY: AUTOMATIC BRAKE 8329797 (19207)	EA	1	*	*	*	*	*	*	*	*	7	38
P-F	5310-335-4667	NUT,ASSEMBLY: AUTOMATIC BRAKE 8328119 (19207)	EA	1	*	*	*	*	*	*	*	*	7	38
P-F	5310-627-6128	WASHER,LOCK: AUTOMATIC BRAKE 138489 (21450)	EA	2	*	*	*	*	*	*	*	*	7	39
P-F	5305-012-3520	BOLT: AUTOMATIC BRAKE 123520 (50513)	EA	2	*	*	*	*	*	*	*	*	7	40
P-F	5310-022-5831	NUT,PLAIN,HEXAGON: GEAR PLATE 225831 (21450)	EA	4	*	*	*	*	*	*	*	*	7	41
P-F		SEAL,HELICAL,COMPRESSION: AUTOMATIC BRAKE 7734926 (19207)	EA	4	*	*	*	*	*	*	*	*	7	42
P-F	2590-693-0224	SPRING,HELICAL COMPRESSION: AUTOMATIC BRAKE 7701751 (19207)	EA	4	*	*	*	*	*	*	*	*	7	43
P-F	5995-999-4375	WASHER: GEAR PLATE 120394 (13190)	EA	4	*	*	*	*	*	*	*	*	7	44
P-F	2540-770-6879	SLEEVE: THRUST BEARING 7706879 (19207)	EA	1	*	*	*	*	*	*	*	*	7	45
P-F	3110-142-4351	CONE AND ROLLERS,TAPERED: WORM DRIVE 137178 (24617)	EA	2	*	*	*	*	*	*	*	*	7	46
P-F	3110-100-0599	CUP,TAPERED ROLLER: WORM DRIVE 120728 (24617)	EA	2	*	*	*	*	*	*	*	*	7	47
X2-F		SPACER: WORM DRIVE HG110E66 (74340)	EA	1	*	*	*	*	*	*			7	48

(1) SMR Code	(2) Federal Stock Number	(3) DESCRIPTION	(4) UNIT of meas	(5) Qty inc. in Unit	(6) 30-day DS maint allowance	(7) 30-day GS maint allowance	(8) 1-yr alw per 100 equip cnt- gcy	(9) Depot maint alw per 100 equip	(10) Illustration No.	(a) Figure No.	(b) Item No.	
Reference Number & Mfr. Code			Usable On Code			(a)	(b)	(c)	(a)	(b)	(c)	
						1-20	21-50	51-100	1-20	21-50	51-100	
		2001-WINCH ASSEMBLY-CONTINUED										
P-F	3110-407-2777	PLATE,RETAINING,BEARING: WORM DRIVE 7701025 (19207)	EA	1	*	*	*	*	*	*	7	49
X2-F		SCREW: RETAINING PLATE HG133E17 (74340)	EA	4	*	*	*	*	*	*	7	50
P-F	3830-995-4357	SPACER,SLEEVE: WORM DRIVE 119E65 (74340)	EA	1	*	*	*	*	*	*	7	51
X2-F		SPACER: WORM DRIVE 119E69 (74340)	EA	2	*	*	*	*	*	*	7	52
P-O	3830-318-0929	SPROCKET,WHEEL: WORM DRIVE 8329807 (19207)	EA	1	*	*	*	*	*	*	7	53
P-O		SCREW: DRIVE SPROCKET HG250B79 (74340)	EA	1	*	*	*	*	*	*	7	54
X2-F		SPACER: DRIVE SPROCKET HG119E66 (74340)		1	*	*	*	*	*	*	7	55
P-F	5330-050-0156	SEAL,PLAIN,ENCASED: WORM DRIVE 500156 (21450)	EA	1	*	*	*	*	*	*	7	56
P-O	4730-221-2138	PLUG: GEAR CASE MS20913-3S (96906)	EA	1	*	*	*	*	*	*	7	57
P-F	5310-820-6653	WASHER,LOCK: GEAR COVER MS35338-50 (96906)	EA	6	*	*	*	*	*	*	7	58
P-F	5305-696-5255	SCREW,CAP,HEXAGON: GEAR COVER 430114 (21450)	EA	6	*	*	*	*	*	*	7	59
P-O		PLUG: GEAR COVER HG125E45 (74340)	EA	1	*	*	*	*	*	*	7	60
P-F		BOLT: FORK BRACKET 429739 (21450)	EA	2	*	*	*	*	*	*	7	61
X2-F		FRAME: REAR WINCH W2876C (74340)	EA	1	*	*	*	*	*	*	8	1
P-F	5310-021-4267	NUT,PLAIN,HEXAGON: WINCH FRAME 214267 (24617)	EA	4	*	*	*	*	*	*	8	2
P-F	5310-584-5272	WASHER,LOCK: WINCH FRAME MS35338-48 (96906)	EA	4	*	*	*	*	*	*	8	3
X2-F		SPACER: WINCH FRAME 31A587-2 (74340)	EA	4	*	*	*	*	*	*	8	4
X2-F		SUPPORT: WINCH FRAME 165A47 (74340)	EA	2	*	*	*	*	*	*	8	5
P-F	2520-318-0928	SPROCKET: AUXILIARY SHAFT 8329806 (19207)	EA	1	*	*	*	*	*	*	8	6

(1) SMR Code	(2) Federal Stock Number	(3) DESCRIPTION	(4) UNIT of meas	(5) Qty inc. in Unit	(6) 30-day DS maint allowance			(7) 30-day GS maint allowance			(8) 1-yr alw per 100 equip cnt- gcy	(9) Depot maint alw per 100 equip	(10) Illustration	
		Reference Number & Mfr. Code	Usable On Code		(a) 1-20	(b) 21-50	(c) 51-100	(a) 1-20	(b) 21-50	(c) 51-100			(a) Figure No.	(b) Item No.
		2001-WINCH ASSEMBLY-CONTINUED												
P-F		SCREW: BUSHING CAP 139416 (21450)	EA	1	*	*	*	*	*	*	*	*	8	7
P-F	5310-820-6653	WASHER, LOCK: BUSHING CAP MS35338-50 (96906)	EA	8	*	*	*	*	*	*	*	*	8	8
P-F	5305-696-5074	BOLT: CAP TO SUPPORT 429730 (21450)	EA	8	*	*	*	*	*	*	*	*	8	9
P-F	3120-770-1739	BEARING, SLEEVE: DRUM SHAFT 7701739 (19207)	EA	2	*	*	*	*	*	*	*	*	8	10
X2-F		DRUM: REAR WINCH 101W17 (74340)	EA	1	*	*	*	*	*	*	*	*	8	11
P-F	2590-770-1738	COLLAR, SHAFT: DRUM SHAFT 7701738 (192070)	EA	1	*	*	*	*	*	*	*	*	8	12
P-F	3830-995-5821	SPRING, HELICAL, COMPRESSION: DRUM BRAKE 123E43 (74340)	EA	1	*	*	*	*	*	*	*	*	8	13
P-F	5320-013-6593	RIVET, TUBULAR: BRAKE LINING 136593 (21450)	EA	10	*	*	*	*	*	*	*	*	8	14
P-F	2590-773-5940	LINING, FRICTION: DRUM BRAKE 7735940 (19207)	EA	1	*	*	*	*	*	*	*	*	8	15
P-F	3110-622-7035	BALL, BEARING: BRAKE PLATE 607596 (24617)	EA	2	*	*	*	*	*	*	*	*	8	16
P-F	3110-100-6168	BALL, BEARING: BRAKE PLATE 145650 (21450)	EA	2	*	*	*	*	*	*	*	*	8	17
P-F	2540-734-0527	PLUNGER: SPRING TO BALL 607594 (24617)	EA	2	*	*	*	*	*	*	*	*	8	18
P-F	3830-569-8664	SPRING, WINCH CLUTCH: AUXILIARY SHAFT 7340529 (19207)	EA	1	*	*	*	*	*	*	*	*	8	19
P-F	3830-654-2166	SPACER, SLEEVE: AUXILIARY SHAFT 239B65 (74340)	EA	1	*	*	*	*	*	*	*	*	8	20
X2-F		RING: REAR WINCH 123E41 (74340)	EA	1	*	*	*	*	*	*	*	*	8	21
P-F	3120-770-1750	BEARING, SLEEVE: AUXILIARY DRIVE 7701750 (19207)	EA	2	*	*	*	*	*	*	*	*	8	22
P-F	2590-770-1761	WASHER, THRUST: WORM GEAR 7701761 (19207)	EA	2	*	*	*	*	*	*	*	*	8	23
P-F	2520-318-0926	GEAR, WORM WHEEL: DRUM SHAFT 8329794 (19207)	EA	1	*	*	*	*	*	*	*	*	8	24
P-F		WIRE: WORM GEAR 22W1631-110 (80244)	FT	V	*	*	*	*	*	*	*	*	8	25
P-F	5305-692-7128	SETScrew: WORM GEAR TO SHAFT 7368186 (19207)	EA	2	*	*	*	*	*	*	*	*	8	26

(1) SMR Code	(2) Federal Stock Number	(3) DESCRIPTION	(4) UNIT of meas	(5) Qty inc. in Unit	(6) 30-day DS maint allowance	(7) 30-day GS maint allowance	(8) 1-yr alw per 100 equip cnt- gcy	(9) Depot maint alw per 100 equip	(10) Illustration alw per 100 equip	(a) Figure No.	(b) Item No.
Reference Number & Mfr. Code			Usable On Code			(a)	(b)	(c)	(a)	(b)	(c)
						1-20	21-50	51-100	1-20	21-50	51-100
		2001-WINCH ASSEMBLY-CONTINUED									
P-F	4730-289-5176	PLUG: SPACER SLEEVE 444703 (24617)	EA	1	*	*	*	*	*	*	8 27
P-F	5305-335-4669	SCREW,CAPK,DETENT SLEEVE: SPACER SLEEVE 8329802 (19207)	EA	1	*	*	*	*	*	*	8 28
P-F		SCREW: SPACER SLEEVE 437857 (21450)	EA	1	*	*	*	*	*	*	8 29
P-F	5310-017-8601	WASHER,LOCK: SPACER SLEEVE 178601 (24617)	EA	1	*	*	*	*	*	*	8 30
P-F	2540-734-0528	PLATE: CLUTCH DISK 239B66 (73362)	EA	1	*	*	*	*	*	*	8 31
P-F	5315-054-5552	PIN,PAPERED,PLAIN: COLLAR SHAFT 221376 (21450)	EA	1	*	*	*	*	*	*	8 32
P-O	3830-321-6383	CLAMP,WIRE ROPE: DRUM CABLE 8329793 (19207)	EA	1	*	*	*	*	*	*	8 33
P-O	5305-054-4471	SCREW,MACHINE: DRUM CABLE 544471 (21450)	EA	1	*	*	*	*	*	*	8 34
X2-F		PIN: DRUM SHAFT HG110G27 (74340)	EA	1	*	*	*	*	*	*	8 35
X2-F		KEY: DRUM SHAFT 7540181 (19207)	EA	1	*	*	*	*	*	*	8 36
P-F	5315-335-4492	KEY,MACHINE: DRUM SHAFT 7340523 (19207)	EA	2	*	*	*	*	*	*	8 37
X2-F		KEY: DRUM SHAFT 7367933 (19207)	EA	2	*	*	*	*	*	*	8 38
P-F	2530-040-2110	SHAFT: WINCH DRUM W2877C (73362)	EA	1	*	*	*	*	*	*	8 39
P-F	2805-354-4160	BOLT: SUPPORT BRACKET 120235 (64104)	EA	8	*	*	*	*	*	*	8 40
P-F	5310-770-1763	WASHER,FLAT: THRUST,DRUM 7701763 (19207)	EA	1	*	*	*	*	*	*	8 41
P-F	3120-734-0526	BEARING: AUXILIARY SHAFT BRACKET 607563 (24617)	EA	2	*	*	*	*	*	*	8 42
X2-F		CAP: BEARING COVER 11622990 (19207)	EA	2	*	*	*	*	*	*	8 43
P-O	4730-050-4208	FITTING: BEARING AND CAP MS15003-1 (96906)	EA	2	*	*	*	*	*	*	8 44
P-O	2540-040-2107	NON-ILLUSTRATED HOLDER ASSEMBLY: WINCH LINE 8329796 (19207)	EA	1	*	*	*	*	*	*	
P-O	4201-886-040	CLAMP: CABLE TO WINCH 42-C-1860-40 (80244)	EA	1	*	*	*	*	*	*	

(1) SMR Code	(2) Federal Stock Number	(3) DESCRIPTION	(4) UNIT of meas	(5) Qty inc. in Unit	(6) 30-day DS maint allowance			(7) 30-day GS maint allowance			(8) 1-yr alw per 100 equip cnt- gcy	(9) Depot maint alw per 100 equip	(10) Illustration No. (a) (b) Figure Item No. No.	
Reference Number & Mfr. Code			Usable On Code		(a)	(b)	(c)	(a)	(b)	(c)				
					1-20	21-50	51-100	1-20	21-50	51-100				
		2001-WINCH ASSEMBLY-CONTINUED												
P-F	2530-741-2654	LINING SET WINCH: AUTOMATIC BRAKE 7412654 (19207)	EA	1	*	*	*	*	*	*		*		
		CONSISTING OF:												
P-F	2530-753-8730	LINING 2286151 (24617)	EA	1	*	*	*	*	*		*			
P-F	5320-012-1573	RIVET 121573 (24617)	EA	10	*	*	*	*	*		*			
P-F-R	2590-402-5200	WINCH ASSEMBLY: REAR WITH CABLE LEVEL WINDER ITEMS LISTED BELOW ARE APPLICABLE TO REAR WINCH ONLY, UNLESS OTHERWISE INDICATED B USABLE ON CODES INCLUDED IN SECTION I, PARAGRAPH 4D)	EA	1	*	*	*	*	*	*	*	*	9	
		11623130 (19207)												
P-F-R	2590-406-1504	IDLER,ADJUSTABLE WINCH: REAR WINCH DRIVE CHAIN COMPLETE	EA	1	*	*	*	*	*	*	*	*	10	1
		11623064 (19207)												
P-F	3110-289-6824	BEARING ROLLER,TAPER: WITH CUP MS19081-11 (96906)	EA	2	*	*	*	*	*	*	*	*	10	2
P-F	5365-995-8674	RING,RETAINING: BEARING CUP MS16625-193 (96906)	EA	2	*	*	*	*	*	*	*	*	10	3
P-F	3020-477-9880	PULLEY,PLAT: IDLER DRIVE CHAIN 11623065 (19207)	EA	1	*	*	*	*	*	*	*	*	10	4
P-F	5310-194-4791	WASHER,FELT: BEARING RETAINER 11623070 (19207)	EA	2	*	*	*	*	*	*	*	*	10	5
X2-F		RETAINER: BEARING 11623067 (19207)	EA	1	*	*	*	*	*	*			10	6
P-F	5310-842-7783	NUT,PLAIN,BLIND RIVET: MS35692-53 (96906)	EA	1	*	*	*	*	*	*	*	*	10	7
P-O		FITTING: LUBRICATION 186969 (21450)	EA	1	*	*	*	*	*	*	*	*	10	8
P-F	5315-839-5822	PIN, COTTER: MS24665-353 (96906)	EA	1	*	*	*	*	*	*	*	*	10	9
P-F	5305-724-5910	SCREW,CAP,HEXAGON HEAD: MS90725-162 (96906)	EA	4	*	*	*	*	*	*	*	*	10	10
P-F	5310-823-8803	WASHER,PLAT: MS27183-21 (96906)	EA	4	*	*	*	*	*	*	*	*	10	11
P-F	5310-975-2075	NUT,PLAIN,HEXAGON: MS35691-21 (96906)	EA	1	*	*	*	*	*	*	*	*	10	12
P-F	5305-054-9307	SETScrew,SQUARE-HEAD: MS51955-111 (96906)	EA	1	*	*	*	*	*	*	*	*	10	13
X2-O		COVER ASSEMBLY: WELDED FIRST REDUCTIN DRIVE CHAIN 11623073 (19207)	EA	1	*	*	*	*	*	*			11	1

(1) SMR Code	(2) Federal Stock Number	(3) DESCRIPTION	(4) UNIT of meas	(5) Qty inc. in Unit	(6) 30-day DS maint allowance			(7) 30-day GS maint allowance			(8) 1-yr alw per 100 equip cnt- gcy	(9) Depot maint alw per 100 equip	(10) Illustration Figure (a) (b) No. No.	
Reference Number & Mfr. Code			Usable On Code		(a)	(b)	(c)	(a)	(b)	(c)				
					1-20	21-50	51-100	1-20	21-50	51-100				
2001-WINCH ASSEMBLY-CONTINUED														
P-O	5310-595-6326	WASHER,FLAT: CROSS CHAIN COVER MOUNTING (4) SECOND REDUCTION DRIVE CHAIN COVER MOUNTING (1) MS27183-13 (96906)	EA	5	*	*	*	*	*	*	*	*	11	2
P-O	5310-407-9566	WASHER,LOCK: CROSS CHAIN COVER MOUNTING (4) SECOND REDUCTION DRIVE COVER MOUNTING (1) MS35338-45 (96906)	EA	5	*	*	*	*	*	*	*	*	11	3
P-O	5306-225-9089	BOLT,MACHINE: CROSS-CHAIN COVER MOUNTING (4) SECOND REDUCTION DRIVE CHAIN MOUNTING (1) MS90726-34 (96906)	EA	5	*	*	*	*	*	*	*	*	11	4
X2-O		COVER: CROSS CHAIN 11623084 (19207)	EA	1	*	*	*	*	*	*	*	*	11	5
X2-O		COVER ASSEMBLY: WELDED SECOND REDUCTION DRIVE CHAIN 11623079 (19207)	EA	1	*	*	*	*	*	*	*	*	11	6
P-F	5305-269-2801	SCREW,CAP,HEXAGON: SPEED REDUCER AND ADAPTER PLATE MS90726-58 (96906)	EA	2	*	*	*	*	*	*	*	*	12	1
P-F	5310-637-9541	WASHER,LOCK: SPEED REDUCER (4) ADAPTER PLATE (2) MS35338-46 (96906)	EA	6	*	*	*	*	*	*	*	*	12	2
P-F	5305-269-2804	SCREW,CAP,HEXAGON HEAD: SPEED REDUCER MS90726-61 (96906)	EA	4	*	*	*	*	*	*	*	*	12	3
X2-F	3040-431-8340	COLLAR SHAFT: FIRST AND SECOND REDUCTION SPROCKET SHAFT 11621382 (19207)	EA	2	*	*	*	*	*	*	*	*	12	4
P-F	3120-489-0355	BEARING, SLEEVE: FIRST REDUCTION IDLER SPROCKET BRACKET (1) SECOND REDUCTION IDLER SPROCKET BRACKET (1) 11621387 (19207)	EA	2	*	*	*	*	*	*	*	*	12	5
P-F	5305-724-5896	SETSCREW,HEXAGON SOCKET: CHAIN SPROCKET MS51963-82 (96906)	EA	5	*	*	*	*	*	*	*	*	12	6
X2-F		BRACKET: FIRST REDUCTION IDLER SPROCKET SHAFT 11623048 (19207)	EA	1	*	*	*	*	*	*	*	*	12	7
X2-F		CUP,OILER:FIRST AND SECOND REDUCTION IDLER SPROCKET SHAFT BRACKETS 140771 (21450)	EA	4	*	*	*	*	*	*	*	*	12	8
P-F	5305-058-5022	SETSCREW,SQUARE-HEAD: FIRST REDUCTION IDLER SPROCKET BRACKET MS51955-79 (96906)	EA	1	*	*	*	*	*	*	*	*	12	9
P-F	5310-768-0318	NUT,PLAIN,HEXAGON: MS51967-14 (96906)	EA	1	*	*	*	*	*	*	*	*	12	10

(1) SMR Code	(2) Federal Stock Number	(3) DESCRIPTION	(4) UNIT of meas	(5) Qty inc. in Unit	(6) 30-day DS maint allowance	(7) 30-day GS maint allowance	(8) 1-yr alw per 100 equip cnt- gcy	(9) Depot maint alw per 100 equip	(10) Illustration No.	(a) Figure No.	(b) Item No.			
Reference Number & Mfr. Code			Usable On Code			(a) 1-20	(b) 21-50	(c) 51-100	(a) 1-20	(b) 21-50	(c) 51-100			
		2001-WINCH ASSEMBLY-CONTINUED												
P-F	3120-489-0354	BEARING, SLEEVE: FIRST REDUCTION IDLER SPROCKET BRACKET 11621386 (19207)	EA	1	*	*	*	*	*	*	*	*	*	12 11
P-F	3040-356-8707	SHAFT, STRAIGHT: FIRST AND SECOND REDUCTION IDLER SPROCKET 11622962 (19207)	EA	2	*	*	*	*	*	*	*	*	*	12 12
P-F	5315-616-5530	KEY,WOODRUFF: RETAINER FIRST AND SCOND REDUCTION IDLER SPROCKET MS35756-15 (96906)	EA	2	*	*	*	*	*	*	*	*	*	12 13
P-F	3020-406-1482	SPROCKET,WHEEL: FIRST AND SECOND REDUCTION IDLER 11623046 (19207)	EA	2	*	*	*	*	*	*	*	*	*	12 14
P-F	5315-264-3099	KEY,MACHINE: FIRST REDUCTION DRIVE SPROCKET RETAINER MS20066-187 (96906)	EA	1	*	*	*	*	*	*	*	*	*	12 15
P-O		LINK ASSEMBLY: FIRST REDUCTION DRIVE CHAIN ASSEMBLY 11623139-2 (19207)	EA	1	*	*	*	*	*	*	*	*	*	12 16
P-O		CHAIN ASSEMBLY: FIRST REDUCTION DRIVE 11623139-3 (19207)	EA	1	*	*	*	*	*	*	*	*	*	12 17
P-F	5305-724-5833	SETScrew,HEX-SOCKET: WHEEL SPROCKET MS51963-86 (96906)	EA	1	*	*	*	*	*	*	*	*	*	12 18
P-F	3020-406-1480	SPROCKET,WHEEL: SPEED REDUCER INPUT SHAFT 11623045 (19207)	EA	1	*	*	*	*	*	*	*	*	*	12 19
P-F		BEARING: BUSING TYPE SECOND REDUCTION IDLER SPROCKET BRACKET 11621385 (19207)	EA	1	*	*	*	*	*	*	*	*	*	12 20
X2-F		BRACKET: SECOND REDUCTION IDLER SPROCKET SHAFT 11623042 (19207)	EA	1	*	*	*	*	*	*	*	*	*	12 21
P-F	5310-809-3079	WASHER,PLAT: ROD ADJUSTING MS27183-19 (96906)	EA	1	*	*	*	*	*	*	*	*	*	12 22
P-F	5310-834-8732	NUT,PLAIN,HEXAGON: ROD ADJUSTING MS35691-33 (96906)	EA	2	*	*	*	*	*	*	*	*	*	12 23
P-F	3020-449-0517	SPROCKET,WHEEL: SPEED REDUCER OUTPUT SHAFT 11623047 (19207)	EA	1	*	*	*	*	*	*	*	*	*	12 24
P-F	5305-725-4187	SCREW,CAP,HEXAGON HEAD: SECOND REDUCTION IDLER SPROCKET BRACKET ADJUSTING ROD MS90726-114 (96906)	EA	1	*	*	*	*	*	*	*	*	*	12 25
P-F	5310-584-5272	WASHER,LOCK: ADJUSTING ROD MS35338-48 (96906)	EA	1	*	*	*	*	*	*	*	*	*	12 26
P-F	5310-809-5998	WASHER,PLAT: ADJUSTING ROD MS27183-18 (96906)	EA	1	*	*	*	*	*	*	*	*	*	12 27
X2-F		ROD,ADJUSTING: SECOND REDUCTION DRIVE CHAIN 11622949 (19207)	EA	1	*	*	*	*	*	*	*	*	*	12 28



(1) SMR Code	(2) Federal Stock Number	(3) DESCRIPTION	(4) UNIT of meas	(5) Qty inc. in Unit	(6) 30-day DS maint allowance			(7) 30-day GS maint allowance			(8) 1-yr alw per 100 equip cnt- gcy	(9) Depot maint alw per 100 equip	(10) Illustration	
		Reference Number & Mfr. Code	Usable On Code		(a) 1-20	(b) 21-50	(c) 51-100	(a) 1-20	(b) 21-50	(c) 51-100			(a) Figure No.	(b) Item No.
		2001-WINCH ASSEMBLY-CONTINUED												
P-F	5305-269-2802	SCREW, CAP, HEXAGON HEAD: SPEED REDUCER ADAPTER PLATE MS90726-59 (96906)	EA	2	*	*	*	*	*	*	*	*	12	29
P-F	5305-716-8182	SCREW,CAP,HEXAGON HEAD: MAIN DRIVE SUPPORT AND WORM SHAFT BEARING RETAINER MS90726-117 (96906)	EA	2	*	*	*	*	*	*	*	*	12	30
X2-F		SUPPORT: MAIN DRIVE 11623234 (19207)	EA	1	*	*	*	*	*	*			12	31
P-F	5310-823-8803	WASHER,PLAT: MAIN DRIVE SUPPORT MS27183-21 (96906)	EA	1	*	*	*	*	*	*	*	*	12	32
P-F	5310-820-6653	WASHER,LOCK: MAIN DRIVE SUPPORT MS35338-50 (96906)	EA	1	*	*	*	*	*	*	*	*	12	33
P-F	5305-725-4111	SCREW,CAP,HEXAGON HEAD: MAIN DRIVE SUPPORT AND WORM HOUSING COVER MS90726-165 (96906)	EA	1	*	*	*	*	*	*	*	*	12	34
X2-F		PLATE,ADAPTER: SPEED REDUCER 11622948 (19207)	EA	1	*	*	*	*	*	*			12	35
P-F		SPEED REDUCER ASSEMBLY: CABLE LEVEL WINDER 11621389 (19207)	EA	1	*	*	*	*	*	*		*	12	36
P-F	5315-990-2630	KEY,MACHINE: SPEED REDUCER MS20066-252 (96906)	EA	1	*	*	*	*	*	*	*	*	12	37
X2-F		CLIP,SPRING: CHAIN LINK FASTENING 11609932-3 (19207)	EA	2	*	*	*	*	*	*			13	1
P-F	5315-433-2297	PIN,SHOULDER,HEADLESS: CARRIAGE GUIDE 11623057 (19207)	EA	1	*	*	*	*	*	*	*	*	13	2
P-F	5305-724-5896	SETScrew,HEXAGON,SOCKET: CARRIAGE GUIDE PIN RETAINER MS51963-82 (96906)	EA	1	*	*	*	*	*	*	*	*	13	3
P-F	2590-351-2839	GUIDE,CARRIAGE BOOM: CROSS CHAIN 11623058 (19207)	EA	1	*	*	*	*	*	*	*	*	13	4
X2-F		PIN: CROSS-CHAIN CONNECTING 11623054 (19207)	EA	2	*	*	*	*	*	*			13	5
P-O		CHAIN ASSEMBLY: CARRIAGE CROSS 11609932-1 (19207)	EA	1	*	*	*	*	*	*		*	13	6
P-F	3020-406-7290	SPROCKET,WHEEL,TRIPLE: CROSS CHAIN DRIVE 11623059 (19207)	EA	1	*	*	*	*	*	*	*	*	13	7
X2-F		SHAFT: ROLLER CAGE HORIZONTAL ROLLER 11623032 (19207)	EA	1	*	*	*	*	*	*			13	8
X2-F		CAGE,ROLLER: CARRIAGE HORN 11623036 (19207)	EA	1	*	*	*	*	*	*			13	9

(1) SMR Code	(2) Federal Stock Number	(3) DESCRIPTION	(4) UNIT of meas	(5) Qty inc. in Unit	(6) 30-day DS maint allowance			(7) 30-day GS maint allowance			(8) 1-yr alw per 100 equip cnt- gcy	(9) Depot maint alw per 100 equip	(10) Illustration No. (a) (b) Figure Item No. No.	
Reference Number & Mfr. Code			Usable On Code		(a)	(b)	(c)	(a)	(b)	(c)				
					1-20	21-50	51-100	1-20	21-50	51-100				
		2001-WINCH-ASSEMBLY-CONTINUED												
X2-F		PIN,CLEVIS: ROLLER CAGE HORIZONTAL ROLLER 505006 (21450)	EA	1	*	*	*	*	*	*			13	10
X2-F		ROLLER: HORIZONTAL,ROLLER CAGE 11623030 (19207)	EA	2	*	*	*	*	*	*			13	11
X2-F		PLATE: CARRIAGE HORNS 11623125 (19207)	EA	1	*	*	*	*	*	*			13	12
P-F	5310-891-3429	NUT,PLAIN,HEXAGON: PLATE CARRIAGE MS35691-81 (96906)	EA	2	*	*	*	*	*	*	*	*	13	13
P-F	5310-584-7888	WASHER,LOCK: PLATE CARRIAGE MS35338-51 (96906)	EA	2	*	*	*	*	*	*	*	*	13	14
P-F	5310-809-5998	WASHER,FLAT: ROLLER CAGE MS27183-18 (96906)	EA	1	*	*	*	*	*	*	*	*	13	15
P-F	5315-816-1794	PIN,COTTER: HORIZONTAL ROLLER MS24665-285 (96906)	EA	1	*	*	*	*	*	*	*	*	13	16
P-F	5305-058-0761	SETScrew,SQUARE-HEAD: HORIZONTAL ROLLER SHAFT RETAINER MS51955-5 (96906)	EA	1	*	*	*	*	*	*	*	*	13	17
P-F	5315-013-7214	PIN, COTTER: VERTICAL ROLLER SHAFT MS24665-359 (96906)	EA	2	*	*	*	*	*	*	*	*	13	18
X2-F		SHAFT: VERTICAL ROLLER CAGE 11623031 (19207)	EA	2	*	*	*	*	*	*			13	19
X2-F		ROLLER: VERTICAL ROLLER CAGE 11623029 (19207)	EA	2	*	*	*	*	*	*			13	20
X2-F		BEARING,SLEEVE: VERTICAL ROLLER CAGE MS17795-83 (96906)	EA	4	*	*	*	*	*	*			13	21
P-F	5310-997-6903	NUT,PLAIN,HEXAGON: TIE ROD SUPPORT MS35691-93 (96906)	EA	7	*	*	*	*	*	*	*	*	13	22
X2-F		SPACER: TIE ROD SUPPORT 11623086 (19207)	EA	1	*	*	*	*	*	*			13	23
P-F	5305-725-4133	SCREW,CAP,HEXAGON: TIE ROD SUPPORT MS90726-168 (96906)	EA	2	*	*	*	*	*	*	*	*	13	24
P-F	5310-820-6653	WASHER,LOCK: TIE ROD SUPPORT MS35338-50 (96906)	EA	4	*	*	*	*	*	*	*	*	13	25
X2-F		BRACKET: TIE ROD SUPPORT 11623088 (19207)	EA	1	*	*	*	*	*	*			13	26
X2-F		ROD,ADJUSTING: UPPER TIE ROD 11623091 (19207)	EA	1	*	*	*	*	*	*			13	27
X2-F		ROD,ADJUSTING: LOWER TIE ROD 11623090 (19207)	EA	1	*	*	*	*	*	*			13	28
X2-F		SUPPORT: TIE RODS 11623089 (19207)	EA	1	*	*	*	*	*	*			13	29

(1) SMR Code	(2) Federal Stock Number	(3) DESCRIPTION	(4) UNIT of meas	(5) Qty inc. in Unit	(6) 30-day DS maint allowance			(7) 30-day GS maint allowance			(8) 1-yr alw per 100 equip cnt- gcy	(9) Depot maint alw per 100 equip	(10) Illustration No. (a) (b) Figure Item No. No.	
Reference Number & Mfr. Code			Usable On Code		(a)	(b)	(c)	(a)	(b)	(c)				
					1-20	21-50	51-100	1-20	21-50	51-100				
		2001-WINCH ASSEMBLY-CONTINUED												
X2-F		SCREW,ADJUSTING: CROSS CHAIN SPROCKET BRACKET RIGHT HAND 11623087 (19207)	EA	1	*	*	*	*	*	*			13	30
P-F	5305-054-9286	SETSCREW,SQUARE-HEAD: TIE ROD RETAINING MS51955-72 (96906)	EA	2	*	*	*	*	*	*	*	*	13	31
P-F	5310-768-0318	NUT,PLAIN,HEXAGON: TIE ROD RETAINING MS51967-14 (96906)	EA	2	*	*	*	*	*	*	*	*	13	32
P-F	5310-835-2037	NUT,PLAIN,HEXAGON: TIE ROD RETAINING MS35691-53 (96906)	EA	2	*	*	*	*	*	*	*	*	13	33
P-O	5306-225-9087	BOLT,MACHINE: ROLLER GUARD MS90726-32 (96906)	EA	4	*	*	*	*	*	*	*	*	13	34
P-O	5310-407-9566	WASHER,LOCK: ROLLER GUIDE MS35338-45 (96906)	EA	4	*	*	*	*	*	*	*	*	13	35
P-O	5310-595-6326	WASHER,FLAT: ROLLER GUIDE MS27183-13 (96906)	EA	4	*	*	*	*	*	*	*	*	13	36
X2-F		GUARD,ROLLER: 11623027 (19207)	EA	1	*	*	*	*	*	*			13	37
X2-F		SPACER: ROLLER CAGE GUARD 11623028 (19207)	EA	4	*	*	*	*	*	*			13	38
P-F	5305-716-8182	SCREW,CAP,HEXAGON: CROSS CHAIN BRACKET MS90726-117 (96906)	EA	4	*	*	*	*	*	*	*	*	13	39
P-F	3040-402-9579	COLLAR,SHAFT: TRIPLE SPROCKET 11623056 (19207)	EA	1	*	*	*	*	*	*	*	*	13	40
P-F	5305-724-6810	SETSCREW,HEXAGON: TRIPLE SPROCKET COLLAR MS51963-101 (96906)	EA	1	*	*	*	*	*	*	*	*	13	41
P-F	3120-180-7755	BEARING,SLEEVE: CHAIN SPROCKET BRACKET MS17795-161 (96906)	EA	2	*	*	*	*	*	*	*	*	13	42
P-F	2590-351-2838	PLATE,HORN MOUNTING: CROSS-CHAIN GUIDE PIN WEAR 11623053 (19207)	EA	2	*	*	*	*	*	*	*	*	13	43
P-O		CHAIN,ASSEMBLY: SECOND REDUCTION DRIVE 11623139-1 (19207)	EA	1	*	*	*	*	*	*		*	13	44
P-O		LINK ASSEMBLY: CHAIN CONNECTING SECOND REDUCTION DRIVE CHAIN ASSEMBLY 11623139-2 (19207)	EA	1	*	*	*	*	*	*		*	13	45
P-F	5305-724-5833	SETSCREW,HEXAGON SOCKET: WHEEL SPROCKET MS51963-86 (96906)	EA	1	*	*	*	*	*	*	*	*	13	46
P-F	3020-232-6016	SPROCKET,WHEEL: CARRIGE DRIVE 11623061 (19207)	EA	1	*	*	*	*	*	*	*	*	13	47
X2-F		BRACKET: CROSS CHAIN SPROCKET 11623050 (19207)	EA	2	*	*	*	*	*	*			13	48

(1) SMR Code	(2) Federal Stock Number	(3) DESCRIPTION	(4) UNIT of meas	(5) Qty inc. in Unit	(6) 30-day DS maint allowance	(7) 30-day GS maint allowance	(8) 1-yr alw per 100 equip cnt- gcy	(9) Depot maint alw per 100 equip	(10) Illustration alw per 100 equip No.	(a) Figure No.	(b) Item No.
Reference Number & Mfr. Code			Usable On Code			(a)	(b)	(c)	(a)	(b)	(c)
						1-20	21-50	51-100	1-20	21-50	51-100
		2001-WINCH ASSEMBLY-CONTINUED									
X2-F		TIE ROD: LOWER 11623232 (19207)	EA	1	*	*	*	*	*	*	13 49
P-F	5305-269-2810	SCREW,CAP,HEXAGON: LOWER TIE ROD MS90726-68 (96906)	EA	1	*	*	*	*	*	*	13 50
P-F	5310-982-4908	NUT,SELF-LOCKING,HEXAGON: TIE ROD MS21045-6 (96906)	EA	2	*	*	*	*	*	*	13 51
X2-F		SCREW,ADJUSTING: CROSS-CHAIN SPROCKET 11623040 (19207)	EA	1	*	*	*	*	*	*	13 52
P-F	5305-269-2813	SCREW,CAP,HEXAGON: UPPER TIE ROD MS90726-69 (96906)	EA	1	*	*	*	*	*	*	13 53
X2-F		TIE ROD: UPPER 11623062 (19207)	EA	1	*	*	*	*	*	*	13 54
P-F	5310-584-5272	WASHER,LOCK,SPLIT: TIE ROD MS35338-48 (96906)	EA	4	*	*	*	*	*	*	13 55
P-F	5310-732-0560	NUT,PLAIN,HEXAGON: TIE ROD MS51968-14 (96906)	EA	4	*	*	*	*	*	*	13 56
P-F	5315-616-5527	KEY,WOODRUFF: WHEEL SPROCKET RETAINER MS35756-18 (96906)	EA	1	*	*	*	*	*	*	13 57
P-F	3020-406-3417	SPROCKET,WHEEL TRIPLE: CROSS-CHAIN 11623060 (1920)	EA	1	*	*	*	*	*	*	13 58
P-F	5310-489-0357	WASHER,RECESSED: TRIPLE SPROCKET 11623052 (19207)	EA	2	*	*	*	*	*	*	13 59
X2-O		CUP,OILER:CROSS-CHAIN SPROCKET 140771 (21450)	EA	2	*	*	*	*	*	*	13 60
P-F	5310-637-9541	WASHER,LOCK: CARRIAGE ASEMBLY MS35338-46 (96906)	EA	4	*	*	*	*	*	*	13 61
P-F	5305-269-2807	SCREW,CAP,HEXAGON: CARRIAGE MS90726-64 (96906)	EA	4	*	*	*	*	*	*	13 62
X2-F		CARRIAGE ASSEMBLY: 11623128 (19207)	EA	1	*	*	*	*	*	*	13 63
P-F	5305-725-4105	SCREW,CAP,HEXAGON: DRUMSHAFT SUPPORT CAP MS90726-164 (96906)	EA	4	*	*	*	*	*	*	14 1
P-F	5310-820-6653	WASHER,LOCK: DRUMSHAFT SUPPORT CAP MS35338-50 (96906)	EA	4	*	*	*	*	*	*	14 2
P-F	4730-050-4208	FITTING, LUBRICATION: MS15003-1 (96906)	EA	1	*	*	*	*	*	*	14 3
X2-F		CAP: DRUMSHAFT SUPPORT 11622990 (19207)	EA	1	*	*	*	*	*	*	14 4
P-F	5315-011-7869	PIN,STRAIGHT,HEADLESS: SHAFT SUPPORT 117869 (21450)	EA	3	*	*	*	*	*	*	14 5

(1) SMR Code	(2) Federal Stock Number	(3) DESCRIPTION	(4) UNIT of meas	(5) Qty inc. in Unit	(6) 30-day DS maint allowance			(7) 30-day GS maint allowance			(8) 1-yr alw per 100 equip cnt- gcy	(9) Depot maint alw per 100 equip	(10) Illustration No. (a) (b) Figure Item No. No.	
		Reference Number & Mfr. Code	Usable On Code		(a) 1-20	(b) 21-50	(c) 51-100	(a) 1-20	(b) 21-50	(c) 51-100				
		2001-WINCH ASSEMBLY-CONTINUED												
P-F	3120-734-0526	BEARING: DRUMSHAFT-TO-DRUMSHAFT SUPPORT 607563 (24617)	EA	1	*	*	*	*	*	*	*	*	14	6
P-F	2590-770-1738	COLLAR,SHAFT: DRUMSHAFT RETAINING 7701738 (19207)	EA	2	*	*	*	*	*	*	*	*	14	7
P-F	5315-824-2269	PIN, TAPERED, PLAIN: DRUMSHAFT RETAINING COLLAR MS24692-38 (96906)	EA	2	*	*	*	*	*	*	*	*	14	8
P-F	3120-770-1739	BEARING,SLEEVE: WINCH DRUM 7701739 (19207)	EA	2	*	*	*	*	*	*	*	*	14	9
P-F	5315-409-6583	PIN, STRAIGHT, HEADLESS: WINCH DRUMSHAFT 11623022 (19207)	EA	1	*	*	*	*	*	*	*	*	14	10
P-F	3040-356-8619	SHAFT,STRAIGHT: WINCH DRUM 11623019 (19207)	EA	1	*	*	*	*	*	*	*	*	14	11
P-O		SCREW,CAP,HEXAGON: WIRE ROPE CLAMP MS24671-85 (96906)	EA	1	*	*	*	*	*	*	*	*	14	12
P-O	3830-321-6383	CLAMP,WIRE ROPE: 8329793 (19207)	EA	1	*	*	*	*	*	*	*	*	14	13
P-O	4010-491-6990	WIRE ROPE ASSEMBLY: 11623816 (19207)	EA	1	*	*	*	*	*	*	*	*	14	14
P-O	4030-693-0649	HOOK,HOIST: REAR WINCH 8332403 (19207)	EA	1	*	*	*	*	*	*	*	*	14	15
X2-F		DRUM ASSEMBLY: WINCH 11609835 (19207)	EA	1	*	*	*	*	*	*	*	*	14	16
P-F	3120-770-1750	BEARING SLEEVE: DRUMSHAFT-TO-WORM GEAR HOUSING 7701750 (19207)	EA	2	*	*	*	*	*	*	*	*	14	17
P-F	2590-770-1761	BEARING,WASHER THRUST: DRUMSHAFT DRIVE GEAR 7701761 (19207)	EA	2	*	*	*	*	*	*	*	*	14	18
P-F	2540-770-1746	GEAR: DRUMSHAFT DRIVE 7701746 (19207)	EA	1	*	*	*	*	*	*	*	*	14	19
P-F	9505-248-9850	WIRE,STEEL,CARBON: GEAR MS20995P47 (96906)	SL	V	*	*	*	*	*	*	*	*	14	20
P-F	5305-692-7128	SETScrew,WORM WHEEL: SPECIAL 7368186 (19207)	EA	2	*	*	*	*	*	*	*	*	14	21
P-F	5315-951-8695	KEY,MACHINE: WORM GEAR RETAINING MS20068-364 (96906)	EA	1	*	*	*	*	*	*	*	*	14	22
P-F	2590-773-5940	LINING,FRICTION: DRUM BRAKE 7735940 (19207)	EA	1	*	*	*	*	*	*	*	*	14	23
X2-F		SPRING: COMPRESSION BRAKE PLATE 11623006 (19207)	EA	1	*	*	*	*	*	*	*	*	14	24
P-F	2590-443-4861	PLATE,CLUTCH AND BRAKE: 11623004 (19207)	EA	1	*	*	*	*	*	*	*	*	14	25

(1) SMR Code	(2) Federal Stock Number	(3) DESCRIPTION	(4) UNIT of meas	(5) Qty inc. in Unit	(6) 30-day DS maint allowance			(7) 30-day GS maint allowance			(8) 1-yr alw per 100 equip cnt- gcy	(9) Depot maint alw per 100 equip	(10) Illustration	
		Reference Number & Mfr. Code	Usable On Code		(a) 1-20	(b) 21-50	(c) 51-100	(a) 1-20	(b) 21-50	(c) 51-100			(a) Figure No.	(b) Item No.
		2001-WINCH ASSEMBLY-CONTINUED												
X1		BALL: CLUTCH AND BRAKE PLATE(COMPONENT OF KIT,WINCH DRUM CLUTCH AND BRAKE ASSEMBLY,FSN 2590-443-0102) MS150466 (96906)	EA	2									14	26
X1		BALL: CLUTCH AND BRAKE PLATE(COMPONENT OF KIT,WINCH DRUM CLUTCH AND BRAKE ASSEMBLY,FSN 2590-443-0102) MS150471 (96906)	EA	2									14	27
X1		DETENT: CLUTCH AND BRAKE PLATE(COMPONENT OF KIT, WINCH DRUM CLUTCH AND BRAKE ASSEMBLY,FSN 2590-443- 0102) 11623000 (19207)	EA	2									14	28
P-F	5360-448-5299	SPRING,HELICAL: DETENT(COMPONENT OF KIT,WINCH DRUM CLUTCH AND BRAKE ASSEMBY,FSN 2590-443-0102) 11623002 (19207)	EA	1	*	*	*	*	*	*			14	29
P-F	5320-058-2036	RIVET,TUBULAR: CLUTCH AND BRAKE PLATE MS16536-180 (96906)	EA	10	*	*	*	*	*	*	*	*	14	30
P-F	5315-781-2036	KEY,MACHINE: CLUTCH AND BRAKE PLATE MS20068-366 (96906)	EA	2	*	*	*	*	*	*	*	*	14	31
P-F	3830-654-2166	SPACER,SLEEVE: CLUTCH DETENT 239B65 (74340)	EA	1	*	*	*	*	*	*	*	*	14	32
X2-F		RING,STOP: CLUTCH DETENT SLEEVE 123E41 (74340)	EA	1	*	*	*	*	*	*	*	*	14	33
P-F	5320-067-5840	RIVET,SOLID: STOP RING MS20613-8P10 (96906)	EA	1	*	*	*	*	*	*	*	*	14	34
P-F	4730-289-5176	PLUG,PIPE: SLEEVE DETENT(COMPONENT OF KIT,WINCH DRUM CLUTCH AND BRAKE ASSEMBLY,FSN 2590-443-0102) MS49005-8 (96906)	EA	1	*	*	*	*	*	*	*	*	14	35
P-F		SCREW,MACHINE,PAN-HEAD: RING STOP 439534 (21450)	EA	1	*	*	*	*	*	*	*	*	14	36
P-F	5310-209-5116	WASHER,LOCK: RING STOP MS35335-37 (96906)	EA	2	*	*	*	*	*	*	*	*	14	37
P-F	5305-335-4669	SCREW,CAP,DETENT: RING STOP 8329802 (19207)	EA	1	*	*	*	*	*	*	*	*	14	38
X2-F		FRAME ASSEMBLY: WINCH MOUNTING 11623018 (19207)	EA	1	*	*	*	*	*	*	*	*	14	39
P-F	2590-406-7296	TENSION ROLLER,WINCH: CABLE 11609808 (19207)	EA	1	*	*	*	*	*	*	*	*	14	40
P-F	5305-725-4183	SCREW,CAP,HEXAGON: FRAME ASSEMBLY MS90726-113 (96906)	EA	3	*	*	*	*	*	*	*	*	14	41
P-F	5310-067-9507	NUT,SELF-LOCKING,HEXAGON: FRAME ASSEMBLY MS51922-37 (96906)	EA	3	*	*	*	*	*	*	*	*	14	42

(1) SMR Code	(2) Federal Stock Number	(3) DESCRIPTION	(4) UNIT of meas	(5) Qty inc. in Unit	(6) 30-day DS maint allowance			(7) 30-day GS maint allowance			(8) 1-yr alw per 100 equip cnt- gcy	(9) Depot maint alw per 100 equip	(10) Illustration	
		Reference Number & Mfr. Code	Usable On Code		(a) 1-20	(b) 21-50	(c) 51-100	(a) 1-20	(b) 21-50	(c) 51-100			(a) Figure No.	(b) Item No.
		2001-WINCH ASSEMBLY-CONTINUED												
P-F	5310-499-0531	WASHER,BEVEL: FRAME ASSEMBLY 7727462 (19207)	EA	11	*	*	*	*	*	*	*	*	14	43
X2-F		SUPPORT: DRUMSHAFT 11622991 (19207)	EA	1	*	*	*	*	*	*	*	*	14	44
P-F	5305-725-4187	SCREW,CAP,HEXAGON: DRUMSHAFT MS90726-114 (96906)	EA	8	*	*	*	*	*	*	*	*	14	45
P-F	5305-727-8810	SCREW,CAP,HEXAGON: RING RETAINING MS90726-185 (96906)	EA	1	*	*	*	*	*	*	*	*	15	1
P-F	5310-584-7888	WASHER,LOCK,SPLIT: RING RETAINING MS35338-51 (96906)	EA	1	*	*	*	*	*	*	*	*	15	2
P-F	5365-159-2188	RING,RETAINING: SPROCKET MS16624-225 (96906)	EA	1	*	*	*	*	*	*	*	*	15	3
P-O	5315-839-5820	PIN,COTTER: SPROCKET MS24665-134 (96906)	EA	2	*	*	*	*	*	*	*	*	15	4
P-O	5315-252-5669	PIN,STRAIGHT,HEADLESS: WINCH DRIVE SPROCKET SHEAR 11609886 (19207)	EA	1	*	*	*	*	*	*	*	*	15	5
P-F	3020-406-4585	SPROCKET,WHEEL: WINCH DRIVE 11609888 (19207)	EA	1	*	*	*	*	*	*	*	*	15	6
P-F	5315-732-0578	KEY,MACHINE: WINCH SPROCKET SLEEVE MS20066-304 (96906)	EA	1	*	*	*	*	*	*	*	*	15	7
P-O	4730-172-0028	FITTING,LUBRICATION: WHEEL SPROCKET MS15003-4 (96906)	EA	1	*	*	*	*	*	*	*	*	15	8
P-F	2590-351-2896	SLEEVE,WINCH SPROCKET: 11609887 (19207)	EA	1	*	*	*	*	*	*	*	*	15	9
P-F	5305-984-7363	SCREW,MACHINE COUNTER SUNK-HEAD: RETAINING OIL SEAL PLATE MS35191-272 (96906)	EA	4	*	*	*	*	*	*	*	*	15	10
P-F	5310-576-5752	WASHER,LOCK: RETAINING OIL SEAL PLATE MS35333-39 (96906)	EA	4	*	*	*	*	*	*	*	*	15	11
P-F	5310-409-4063	WASHER SET: WORM DRIVE SPROCKET SLEEVE 7701015 (19207)	EA	V	*	*	*	*	*	*	*	*	15	12
X2-F	5365-491-9664	SPACER,SLEEVE: WORM DRIVE SPROCKET 7701757 (19207)	EA	1	*	*	*	*	*	*	*	*	15	13
X2-F		PLATE: RETAINING OIL SEAL 11622971 (19207)	EA	1	*	*	*	*	*	*	*	*	15	14
P-F	5330-050-0156	SEAL,PLAIN,ENCASED: OIL WORM THRUST BEARING RETAINER 500156 (21450)	EA	1	*	*	*	*	*	*	*	*	15	15
P-F	3110-407-2777	PLATE,RETAINING: WORM THRUST BEARING 7701025 (19207)	EA	1	*	*	*	*	*	*	*	*	15	16

(1) SMR Code	(2) Federal Stock Number	(3) DESCRIPTION	(4) UNIT of meas	(5) Qty inc. in Unit	(6) 30-day DS maint allowance	(7) 30-day GS maint allowance	(8) 1-yr alw per 100 equip cnt- gcy	(9) Depot maint alw per 100 equip	(10) Illustration alw per 100 equip	(a) Figure No.	(b) Item No.
Reference Number & Mfr. Code			Usable On Code			(a)	(b)	(c)	(a)	(b)	(c)
						1-20	21-50	51-100	1-20	21-50	51-100
		2001-WINCH ASSEMBLY-CONTINUED									
P-F	5305-948-9938	SCREW,CAP,HEXAGON: WORM SHAFT BEARING RETAINER MS51096-14 (96906)	EA	2	*	*	*	*	*	*	15 17
P-F	9505-248-9850	WIRE,STEEL: SCREW RETAINING MS90995F47 (96906)	FT	V	*	*	*	*	*	*	15 18
P-F	2590-770-1749	GASKET: ROLLER BEARING CAGE 7701749 (19207)	EA	3	*	*	*	*	*	*	15 19
P-F	3110-100-5817	BEARING,ROLLER TAPER: TAPERED ROLLER 703162 (19207)	EA	2	*	*	*	*	*	*	15 20
P-F	3110-142-4352	CONE: WORM THRUST BEARING 705527 (19207)	EA	2	*	*	*	*	*	*	15 21
P-F	3110-100-0599	CUP: WORM THRUST BEARING 706915 (19207)	EA	2	*	*	*	*	*	*	15 22
P-F		SHIM SET: WORM THRUST BEARING 7374022 (19207)	EA	V	*	*	*	*	*	*	15 23
X2-F		SPACER: WORM THRUST BEARING 11622959 (19207)	EA	1	*	*	*	*	*	*	15 24
P-F	3130-242-5550	HOUSING,BEARING UNIT: 11623368 (19207)	EA	1	*	*	*	*	*	*	15 25
P-O	4730-221-2138	PLUG,PIPE,SQUARE-HEAD: WORM HOUSING MS20913-3S (96906)	EA	2	*	*	*	*	*	*	15 26
X2-F		HOUSING: WORM 11622981 (19207)	EA	1	*	*	*	*	*	*	15 27
P-F	2590-770-1753	GASKET: WORM GEAR HOUSING-TO-COVER 7701753 (19207)	EA	2	*	*	*	*	*	*	15 28
X2-F		COVER: WORM HOUSING 7701745 (19207)	EA	1	*	*	*	*	*	*	15 29
P-F	5310-820-6653	WASHER,LOCK: WORM HOUSING MS35338-50 (96906)	EA	6	*	*	*	*	*	*	15 30
P-F	5305-725-4111	SCREW,CAP,HEXAGON: WORM HOUSING MS90726-165 (96906)	EA	2	*	*	*	*	*	*	15 31
P-O	4820-726-4719	VALVE,AIR PRESSURE: 5196397 (19207)	EA	1	*	*	*	*	*	*	15 32
P-O	4730-202-6692	BUSHING,PIPE: REDUCER 127956 (19207)	EA	1	*	*	*	*	*	*	15 33
X2-F		BUSHING,REDUCER: 144057 (21450)	EA	1	*	*	*	*	*	*	15 34
P-F	5305-725-4098	SCREW,CAP,HEXAGON: REDUCER MS90726-160 (96906)	EA	1	*	*	*	*	*	*	15 35



(1) SMR Code	(2) Federal Stock Number	(3) DESCRIPTION	(4) UNIT of meas	(5) Qty inc. in Unit	(6) 30-day DS maint allowance			(7) 30-day GS maint allowance			(8) 1-yr alw per 100 equip cnt- gcy	(9) Depot maint alw per 100 equip	(10) Illustration No. (a) (b) Figure Item No. No.	
Reference Number & Mfr. Code			Usable On Code		(a)	(b)	(c)	(a)	(b)	(c)				
					1-20	21-50	51-100	1-20	21-50	51-100				
		2001-WINCH ASSEMBLY-CONTINUED												
P-F	2520-401-9548	WORM SHAFT ASSEMBLY: WINCH DRIVE	EA	1	*	*	*	*	*	*	*	*	15	36
		11622964 (19207)												
X1		1-WORM: WINCH DRIVE											15	37
		11622986 (19207)												
X1		1-STUD: WORM AUTOMATIC BRAKE											15	38
		11622951 (19207)												
P-F	2590-443-4860	STOP AUTOMATIC BRAKE:	EA	1	*	*	*	*	*	*	*	*	15	39
		11622965 (19207)												
P-F	5315-145-1872	PIN,STRAIGHT,HEADLESS: STOP SLEEVE	EA	1	*	*	*	*	*	*	*	*	15	40
		11623055 (19207)												
P-F	5305-792-2864	SCREW,CAP,HEXAGON: WORM SHAFT RETAINER BEARING	EA	4	*	*	*	*	*	*	*	*	15	41
		MS51096-5 (96906)												
X2-F	3110-463-3882	PLATE,RETAINING BEARING: WORM SHAFT ROLLER	EA	1	*	*	*	*	*	*	*	*	15	42
		11622974 (19207)												
P-F		BEARING ASSEMBLY: ROLLER SHAFT	EA	1	*	*	*	*	*	*	*	*	15	43
		11621390 (19207)												
P-F	5305-725-4152	SCREW,CAP,HEXAGON: CLUTCH SHIFTER FORK	EA	2	*	*	*	*	*	*	*	*	15	44
		MS90726-174 (96906)												
P-F	5310-637-9541	WASHER,LOCK: CLUTCH SHIFTER FORK	EA	3	*	*	*	*	*	*	*	*	15	45
		MS35338-46 (96906)												
P-F	5305-269-2803	SCREW,CAP,HEXAGON: CLUTCH SHIFTER FORK	EA	1	*	*	*	*	*	*	*	*	15	46
		MS90726-60 (96906)												
P-O	4730-050-4208	FITTING,LUBRICATION: STRAIGHT	EA	2	*	*	*	*	*	*	*	*	15	47
		MS15003-1 (96906)												
P-F	5315-732-2835	KEY,MACHINE: CLUTCH SHIFTER SHAFT	EA	1	*	*	*	*	*	*	*	*	15	48
		MS20066-261 (96906)												
P-F	3040-356-8695	SHAFT,STRAIGHT: CLUTCH SHIFTER FORK	EA	1	*	*	*	*	*	*	*	*	15	49
		11623011 (19207)												
P-F	5315-198-5986	PIN,TAPERED,PLAIN: LEVER REMOTE CONTROL	EA	1	*	*	*	*	*	*	*	*	15	50
		MS24692-331 (96906)												
P-F	3040-402-5188	LEVER,REMOTE CONTROL: CLUTCH SHIFTER FORK SHAFT	EA	1	*	*	*	*	*	*	*	*	15	51
		11622999 (19207)												
P-F	5320-051-8614	RIVET,SOLID: WINCH CLUTCH FORK	EA	1	*	*	*	*	*	*	*	*	15	52
		MS20613-8P28 (96906)												
P-F	2590-489-2558	FORK,CLUTCH WINCH:	EA	1	*	*	*	*	*	*	*	*	15	53
		11623010 (19207)												
P-F	5315-282-0328	PIN,STRAIGHT: CLUTCH OPERATING	EA	2	*	*	*	*	*	*	*	*	15	54
		8329798 (19207)												
X2-F		BRACKET: CLUTCH SHIFTER FORK	EA	1	*	*	*	*	*	*	*	*	15	55
		11623005 (19207)												

(1) SMR Code	(2) Federal Stock Number	(3) DESCRIPTION	(4) UNIT of meas	(5) Qty inc. in Unit	(6) 30-day DS maint allowance			(7) 30-day GS maint allowance			(8) 1-yr alw per 100 equip cnt- gcy	(9) Depot maint alw per 100 equip	(10) Illustration	
					(a) 1-20	(b) 21-50	(c) 51-100	(a) 1-20	(b) 21-50	(c) 51-100			(a) Figure No.	(b) Item No.
		Reference Number & Mfr. Code												
		2001-WINCH ASSEMBLY-CONTINUED												
P-F	5310-809-4061	WASHER,FLAT: CLUTCH SHIFTER FORK BRACKET MS27183-15 (96906)	EA	1	*	*	*	*	*	*	*	*	15	56
P-F	5306-207-2436	BOLT,MACHINE: WORM AUTOMATIC BRAKE PRESSURE PLATE ADJUSTING 7701752 (19207)	EA	4	*	*	*	*	*	*	*	*	15	57
P-F	5315-842-3044	PIN,COTTER: PRESSURE PLATE ADJUSTING MS24665-283 (96906)	EA	4	*	*	*	*	*	*	*	*	15	58
P-F	5310-080-6004	WASHER,FLAT: PRESSURE PLATE ADJUSTING MS27183-14 (96906)	EA	4	*	*	*	*	*	*	*	*	15	59
P-F	2590-693-0224	SPRING,HELICAL: PRESSURE PLATE ADJUSTING 7701751 (19207)	EA	4	*	*	*	*	*	*	*	*	15	60
X2-F		THIMBLE: PRESSURE PLATE SPRING 7734926 (19207)	EA	4	*	*	*	*	*	*	*	*	15	61
P-F	5305-725-4187	SCREW,CAP,HEXAGON: WORM HOUSING MS90726-114 (96906)	EA	8	*	*	*	*	*	*	*	*	15	62
P-O	4730-221-2139	PLUG,PIPE: WORM HOUSING MS20913-4S (96906)	EA	1	*	*	*	*	*	*	*	*	15	63
P-F	5310-499-0531	WASHER,BEVEL: WORM HOUSING 7727462 (19207)	EA	8	*	*	*	*	*	*	*	*	15	64
P-F	5310-067-9507	NUT,SELP-LOCKING: WORM HOUSING MS51922-37 (96906)	EA	8	*	*	*	*	*	*	*	*	15	65
P-F	2590-351-2847	PLATE,WINCH HOUSING: WORM AUTOMATIC BRAKE 8329801 (19207)	EA	1	*	*	*	*	*	*	*	*	15	66
P-F	3830-770-1768	THIMBLE,AUTOMATIC: PRESSURE PLATE TENSION SPRING 7701768 (19207)	EA	2	*	*	*	*	*	*	*	*	15	67
P-F	2530-321-6384	SPRING,HELICAL: PRESSURE PLATE TENSION 8329804 (19207)	EA	2	*	*	*	*	*	*	*	*	15	68
P-F	2590-406-1507	PLATE,WINCH DRIVE: WORM AUTOMATIC BRAKE LINING 8329800 (19207)	EA	2	*	*	*	*	*	*	*	*	15	69
P-F	2530-318-0916	LINING: AUTOMATIC BRAKE 8328120 (19207)	EA	2	*	*	*	*	*	*	*	*	15	70
P-F	5305-269-2801	SCREW,CAP,HEXAGON: SPACER PLATE MS90726-58 (96906)	EA	2	*	*	*	*	*	*	*	*	15	71
P-F	5365-252-5672	SPACER,PLATE: WORM AUTOMATIC BRAKE STOP RETAINING 11622978 (19207)	EA	1	*	*	*	*	*	*	*	*	15	72
P-F	5330-196-2741	GASKET: AUTOMATIC BRAKE STOP PIN RETAINING PLATE 7735524 (19207)	EA	1	*	*	*	*	*	*	*	*	15	73
P-F	5315-145-1873	PIN,STRAIGHT: AUTOMATIC BRAKE WORM STOP 8329799 (19207)	EA	1	*	*	*	*	*	*	*	*	15	74
P-F	2590-406-1508	WORM BRAKE,WINCH: 11622922 (19207)	EA	1	*	*	*	*	*	*	*	*	15	75

(1) SMR Code	(2) Federal Stock Number	(3) DESCRIPTION	(4) UNIT of meas	(5) Qty inc. in Unit	(6) 30-day DS maint allowance			(7) 30-day GS maint allowance			(8) 1-yr alw per 100 equip cnt- gcy	(9) Depot maint alw per 100 equip	(10) Illustration	
					(a) 1-20	(b) 21-50	(c) 51-100	(a) 1-20	(b) 21-50	(c) 51-100			(a) Figure No.	(b) Item No.
		Reference Number & Mfr. Code												
		2001-WINCH ASSEMBLY-CONTINUED												
P-F	5330-178-9237	SEAL,PLAIN ENCASED: OIL BEARING CAGE 11621388 (19207)	EA	1	*	*	*	*	*	*	*	*	15	76
P-F	5305-725-4183	SCREW,CAP,HEXAGON: BEARING HOUSING MS90726-113 (96906)	EA	4	*	*	*	*	*	*	*	*	15	77
P-F	5310-584-5272	WASHER,LOCK: BEARING HOUSING MS35338-48 (96906)	EA	4	*	*	*	*	*	*	*	*	15	78
X2-F		STUD: WORM AUTOMATIC BRAKE LINING PLATE GUIDE 7097160 (19207)	EA	2	*	*	*	*	*	*	*	*	15	79
P-F	5310-732-0560	NUT,PLAIN,HEXAGON: WORM AUTOMATIC BRAKE LINING STUD MS51968-14 (96906)	EA	2	*	*	*	*	*	*	*	*	15	80
P-F	5310-732-0559	NUT,PLAIN,HEXAGON: WORM AUTOMATIC BRAKE LINING MS51968-8 (96906)	EA	4	*	*	*	*	*	*	*	*	15	81
P-F	2590-351-2851	HOUSING,BEARING: WORM ROLLER BEARING 7701019 (19207)	EA	1	*	*	*	*	*	*	*	*	15	82
P-O		CHAIN ASSEMBLY,SILENT: WINCH DRIVE 60-DEGREE INVERTED 11623121-1 (19207)	EA	1	*	*	*	*	*	*	*	*	15	83
P-F	5315-842-3044	PIN,COTTER: CONTROL LEVER LINKAGE MS24665-283 (96906)	EA	1	*	*	*	*	*	*	*	*	16	1
P-F	5310-842-1490	NUT,PLAIN,BLIND RIVET: CONTROL LEVER LINKAGE MS35692-37 (96906)	EA	1	*	*	*	*	*	*	*	*	16	2
P-F	5310-809-5998	WASHER,PLAT: CONTROL LEVER LINKAGE MS27183-18 (96906)	EA	1	*	*	*	*	*	*	*	*	16	3
P-F	5315-839-5822	PIN,COTTER: CONTROL ROD BOLT EYE MS24665-353 (96906)	EA	2	*	*	*	*	*	*	*	*	16	4
P-F	5306-464-4763	BOLT,EYE: CONTROL ROD 7540183 (19207)	EA	1	*	*	*	*	*	*	*	*	16	5
P-F	5315-842-3154	PIN,STRAIGHT HEADED: CONTROL ROD MS35810-36 (96906)	EA	2	*	*	*	*	*	*	*	*	16	6
P-F	3040-449-0528	CONNECTING LINK,RIGID: 7374026 (19207)	EA	1	*	*	*	*	*	*	*	*	16	7
P-F	5310-834-8734	NUT,PLAIN,HEXAGON: CONTROL ROD MS35691-37 (96906)	EA	1	*	*	*	*	*	*	*	*	16	8
P-F	5340-177-3957	CLEVIS,ROD END: CONTROL MS35812-11 (96906)	EA	1	*	*	*	*	*	*	*	*	16	9
P-F	3040-402-5190	LEVER,REMOTE CONTROL: 11623024 (19207)	EA	2	*	*	*	*	*	*	*	*	16	10
P-F	5315-616-5530	KEY,WOODRUFF: CONTROL LEVER SHAFT MS35756-15 (96906)	EA	2	*	*	*	*	*	*	*	*	16	11
P-F	5310-984-3807	NUT,SELP-LOCKING: REMOTE CONTROL LEVER MS51922-13 (96906)	EA	2	*	*	*	*	*	*	*	*	16	12

(1) SMR Code	(2) Federal Stock Number	(3) DESCRIPTION	(4) UNIT of meas	(5) Qty inc. in Unit	(6) 30-day DS maint allowance	(7) 30-day GS maint allowance	(8) 1-yr alw per 100 equip cnt- gcy	(9) Depot maint alw per 100 equip	(10) Illustration No. (a) Figure (b) Item No.					
Reference Number & Mfr. Code			Usable On Code			(a)	(b)	(c)	(a)	(b)	(c)			
						1-20	21-50	51-100	1-20	21-50	51-100			
		2001-WINCH ASSEMBLY-CONTINUED												
P-F	3040-356-8615	SHAFT,STRAIGHT: CONTROL LEVER 11623020 (19207)	EA	1	*	*	*	*	*	*	*	*	16	13
P-F	3040-402-5189	LEVER,REMOTE CONTROL: 11623023 (19207)	EA	1	*	*	*	*	*	*	*	*	16	14
P-F	5306-225-9094	BOLT,MACHINE: REMOTE CONTROL LEVER MS90726-39 (96906)	EA	2	*	*	*	*	*	*	*	*	16	15
P-F	2590-443-0102	KIT,WINCH DRUM CLUTCH AND BRAKE ASSEMBLY: 5704138 (19207)	EA	1	*	*	*	*	*	*	*	*		
		COMPOSED OF:												
X1		2-BALL MS150466 (96906)											14	26
X1		2-BALL MS150471 (96906)											14	27
X1		2-DETENT 11623000 (19207)											14	28
P-F	5360-448-5299	SPRING,HELICAL DETENT 11623002 (19207)	EA	1									14	29
P-F	4730-289-5176	PLUG,PIPE MS49005-8 (96906)	EA	1									14	35
		GROUP 22-ACCESSORY ITEMS												
		2210-DATA PLATES AND INSTRUCTION HOLDERS (FRONT WINCH FSN 2590-753-8687)												
		A												
P-O	5305-253-5618	SCREW,DRIVE: PLATE ASSEMBLIES MS21318-27 (96906)	EA	10	*	*	*	*	*	*	*	*	17	1
P-O	2590-913-6879	PLATE,INSTRUCTION: WINCH ASSEMBLY 8690899 (19207)	EA	1	*	*	*	*	*	*	*	*	17	2
P-O	2590-753-8793	PLATE,IDENTIFICATION: WINCH ASSEMBLY 7538793 (19207)	EA	1	*	*	*	*	*	*	*	*	17	3
P-O	2590-634-5269	PLATE,INSTRUCTION: WINCH ASSEMBLY 7994966 (19207)	EA	1	*	*	*	*	*	*	*	*	17	4
P-O	2590-141-1619	PLATE,INSTRUCTION: BRAKE ADJUSTING SCREW 8690900 (19207)	EA	1	*	*	*	*	*	*	*	*	17	5

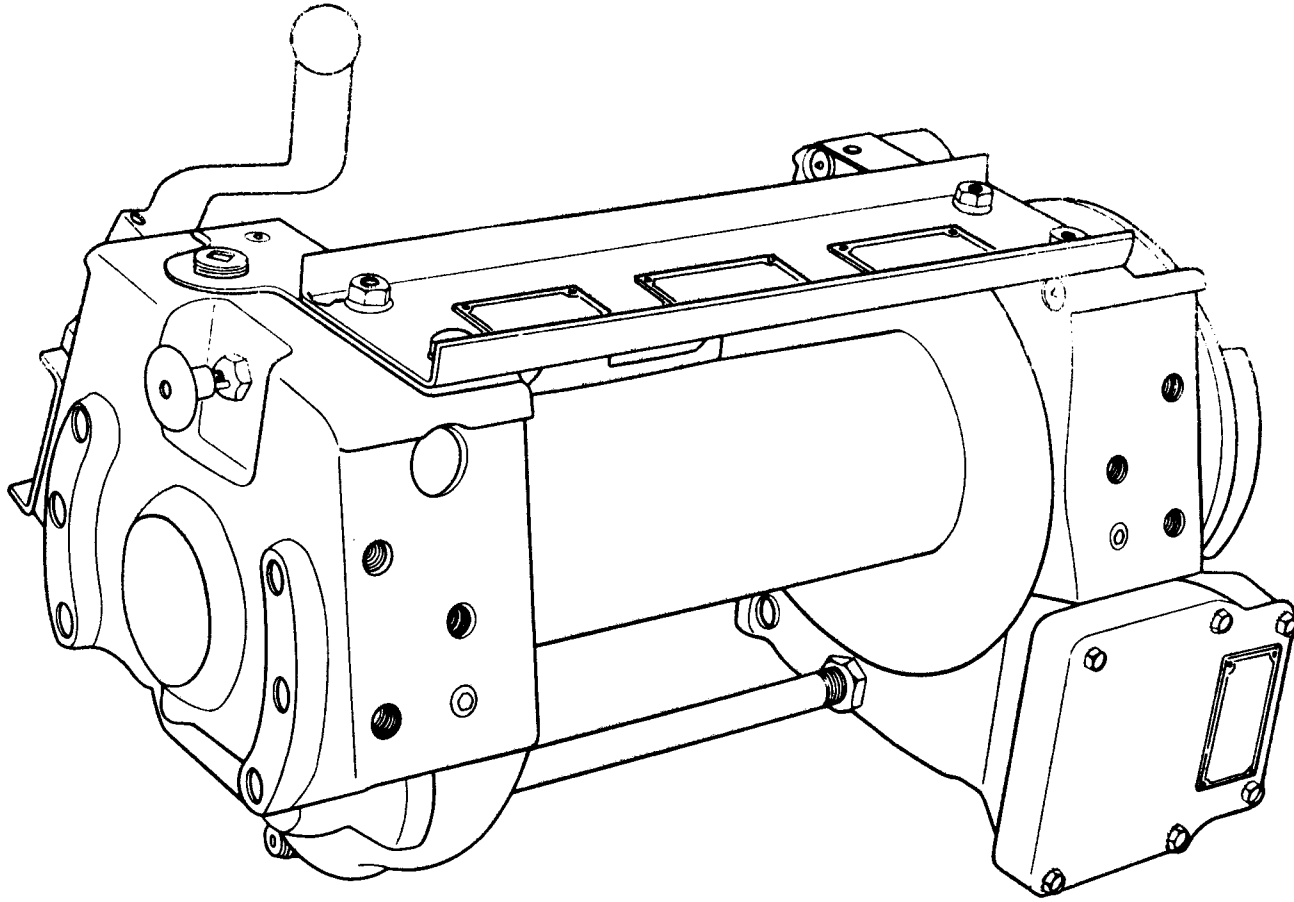

Figure 1. Front winch assembly (FSN 2590-753-8687).

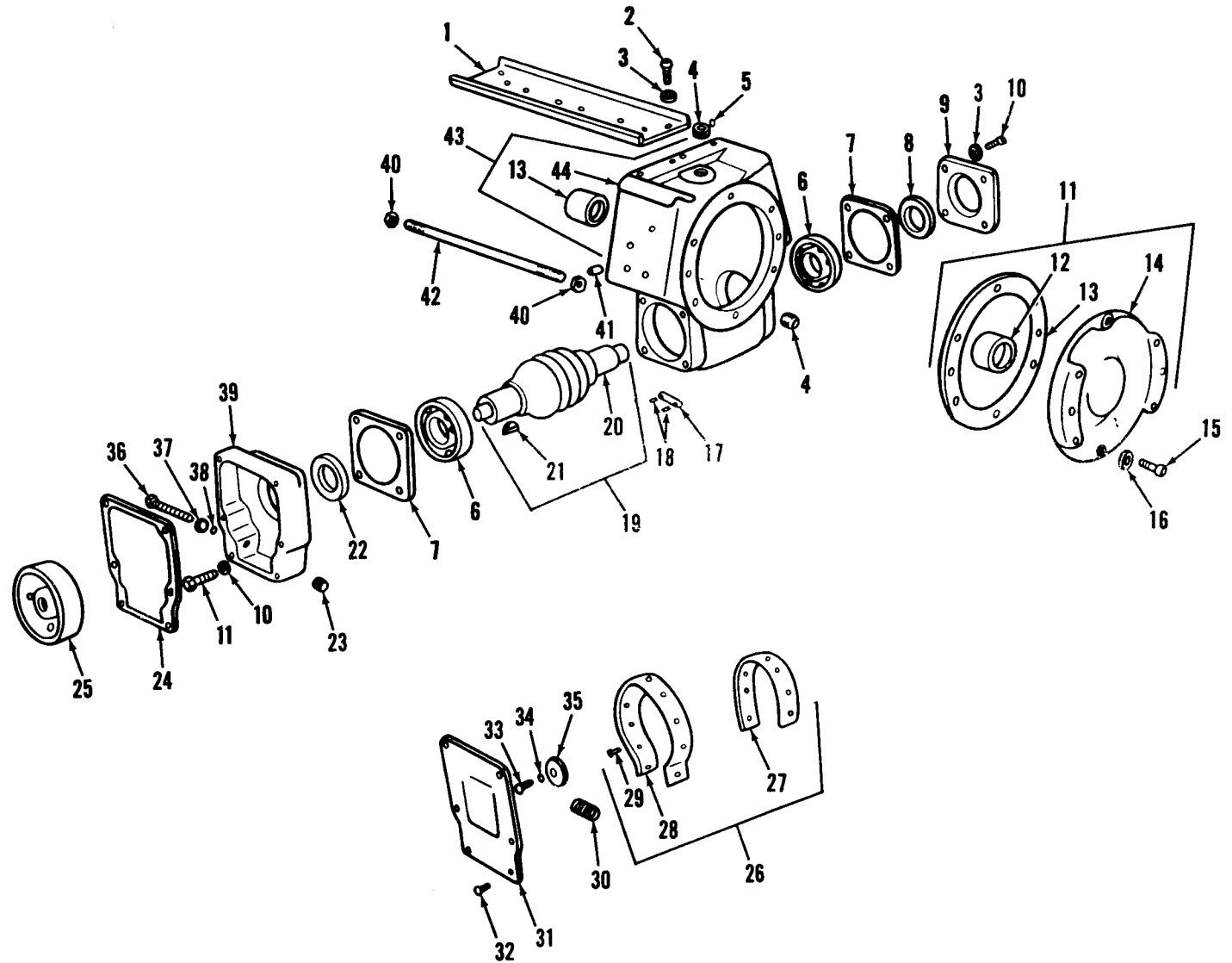

Figure 2. Front winch gear case.

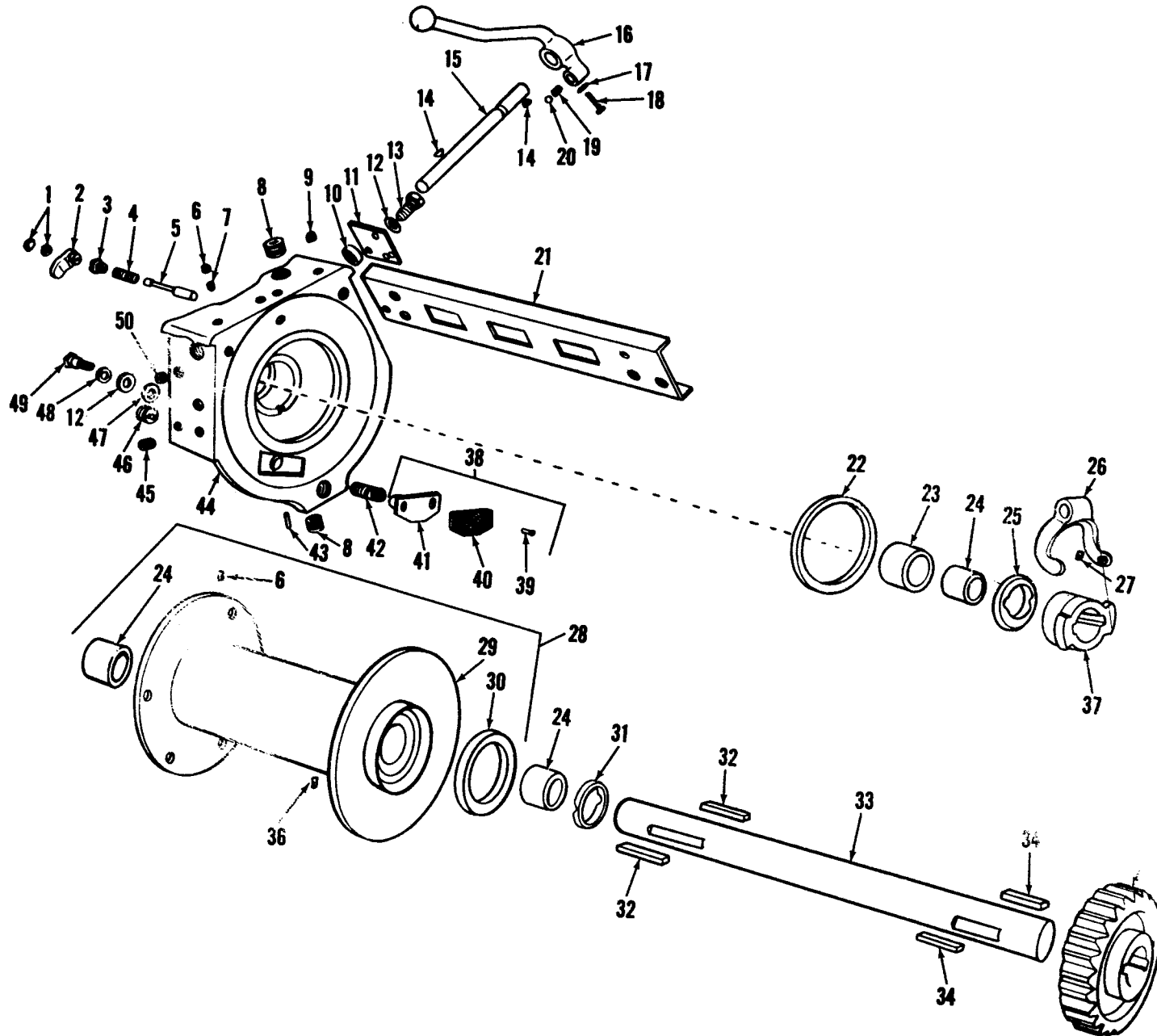

Figure 3. Front winch end plate, drum and shaft.

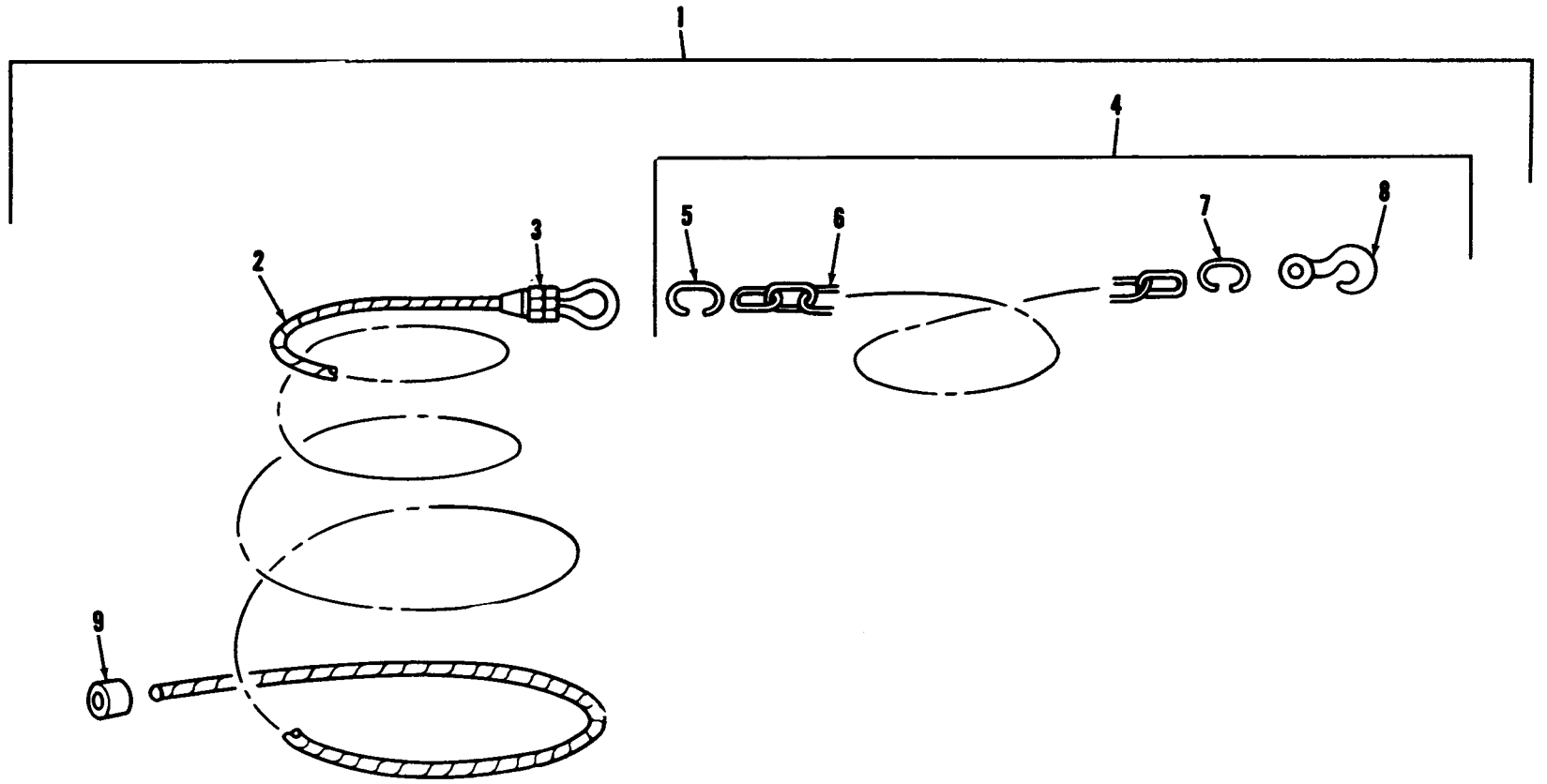
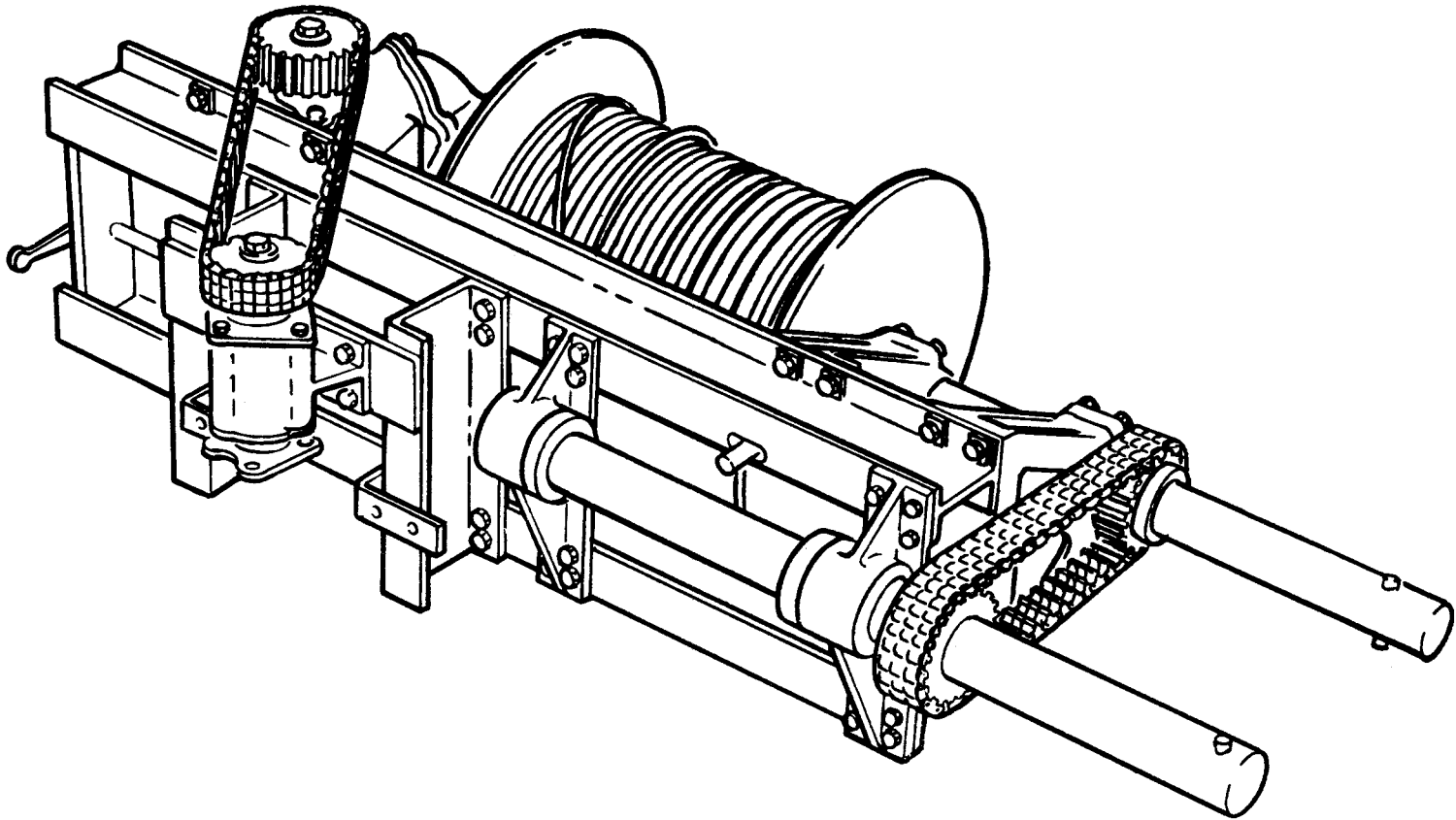

Figure 4. Cable chain and related parts.





AT 40654

Figure 5. Rear winch assembly (FSN 2520-040-2112)—right rear view.

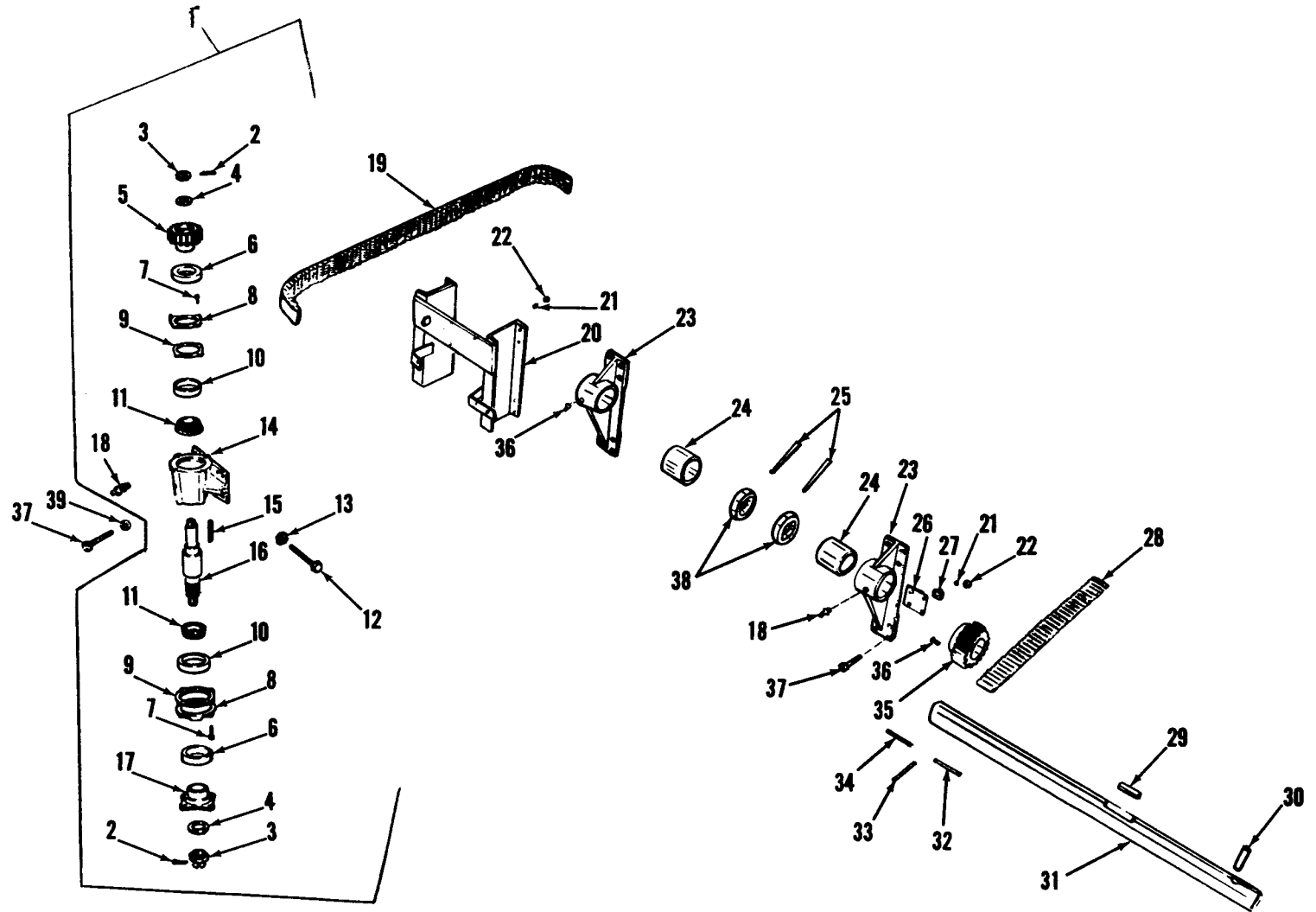

Figure 6. Rear winch pillow block and related parts.

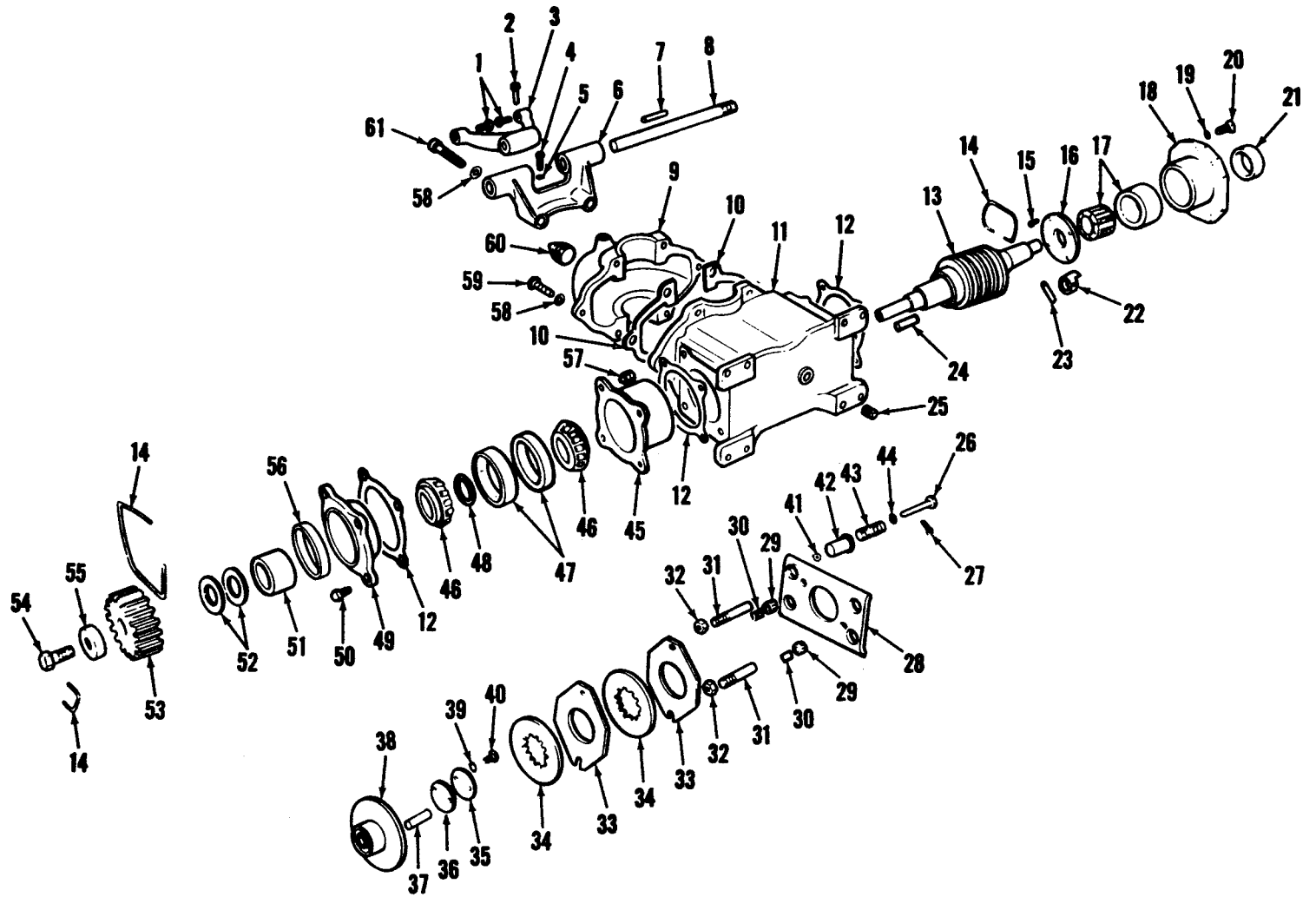

Figure 7. Rear winch gear case.

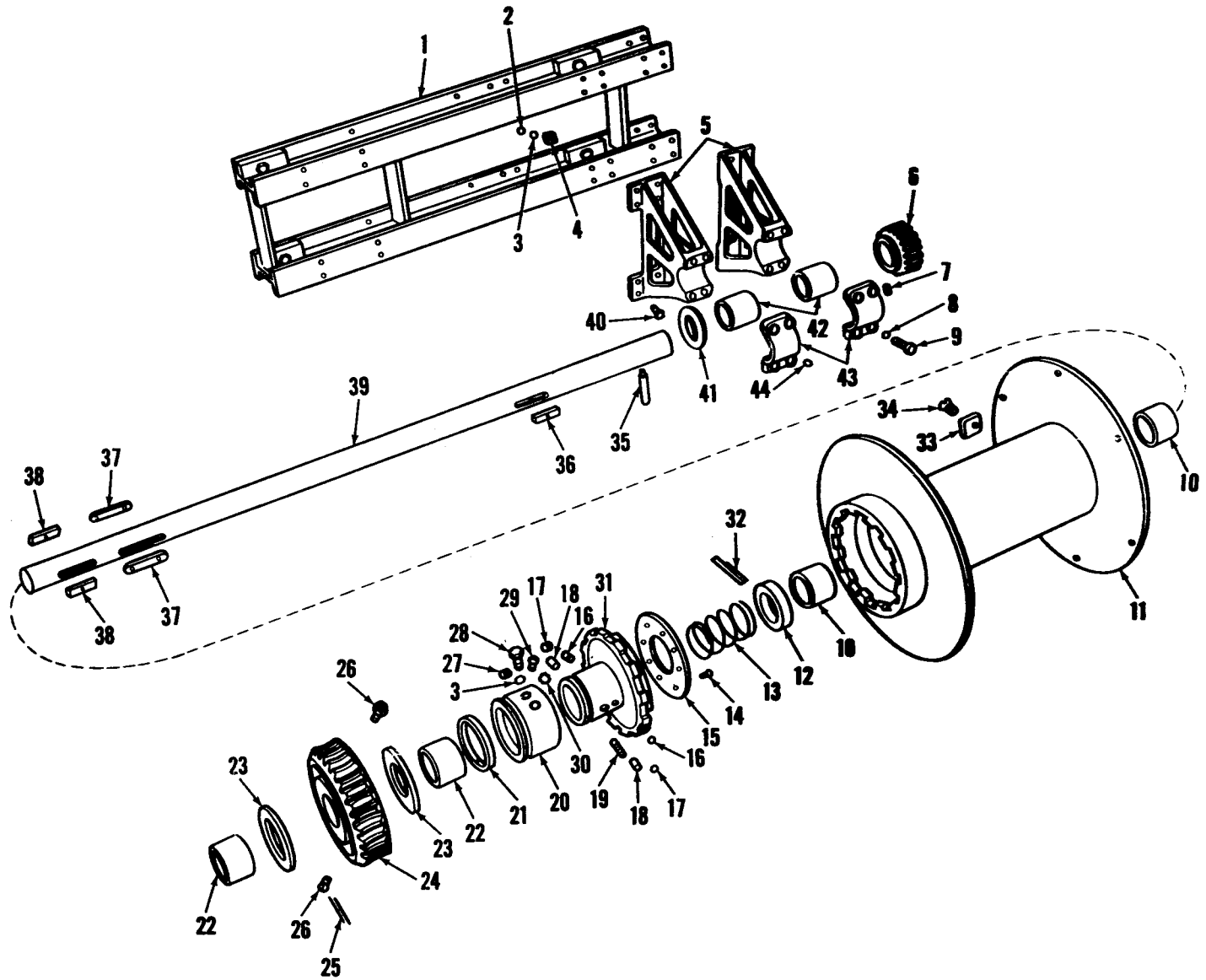
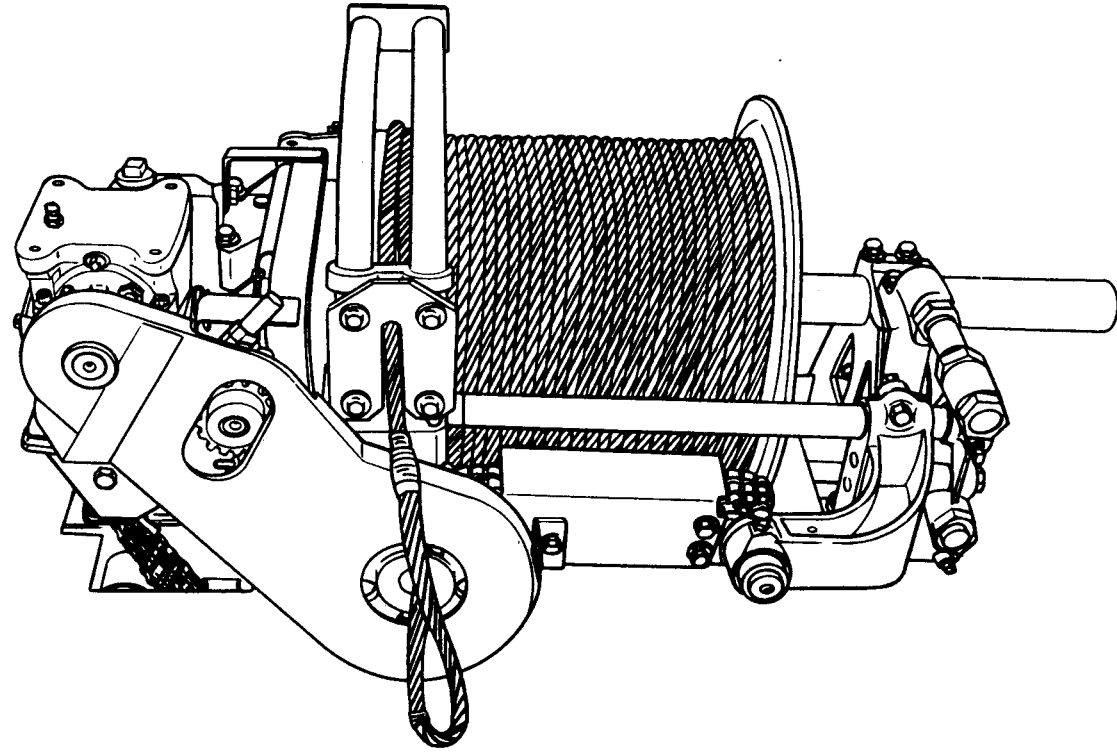

Figure 8. Rear winch drum and clutch.



AT 40658

Figure 9. Rear winch assembly (FSN 2590-402-5200).

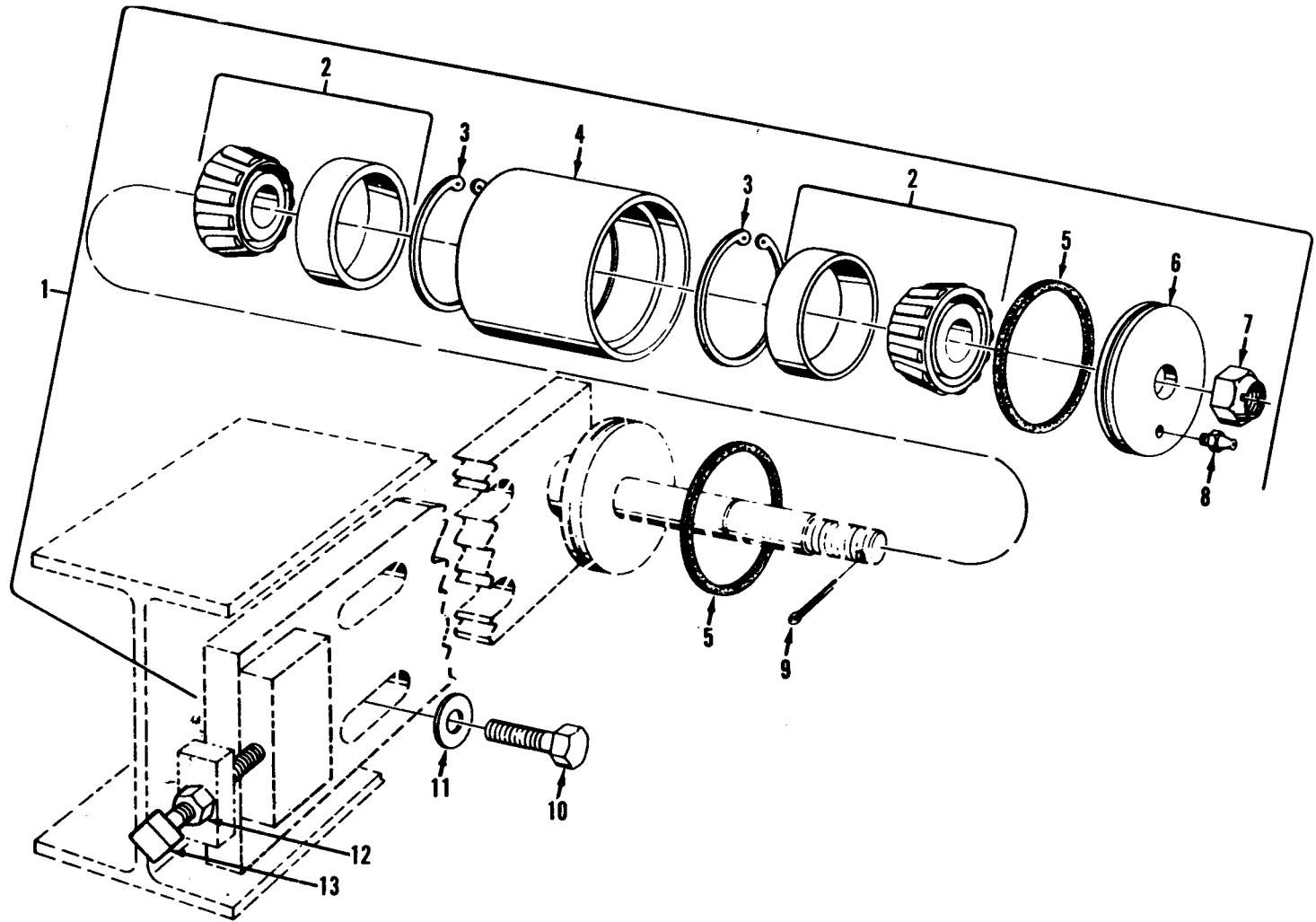
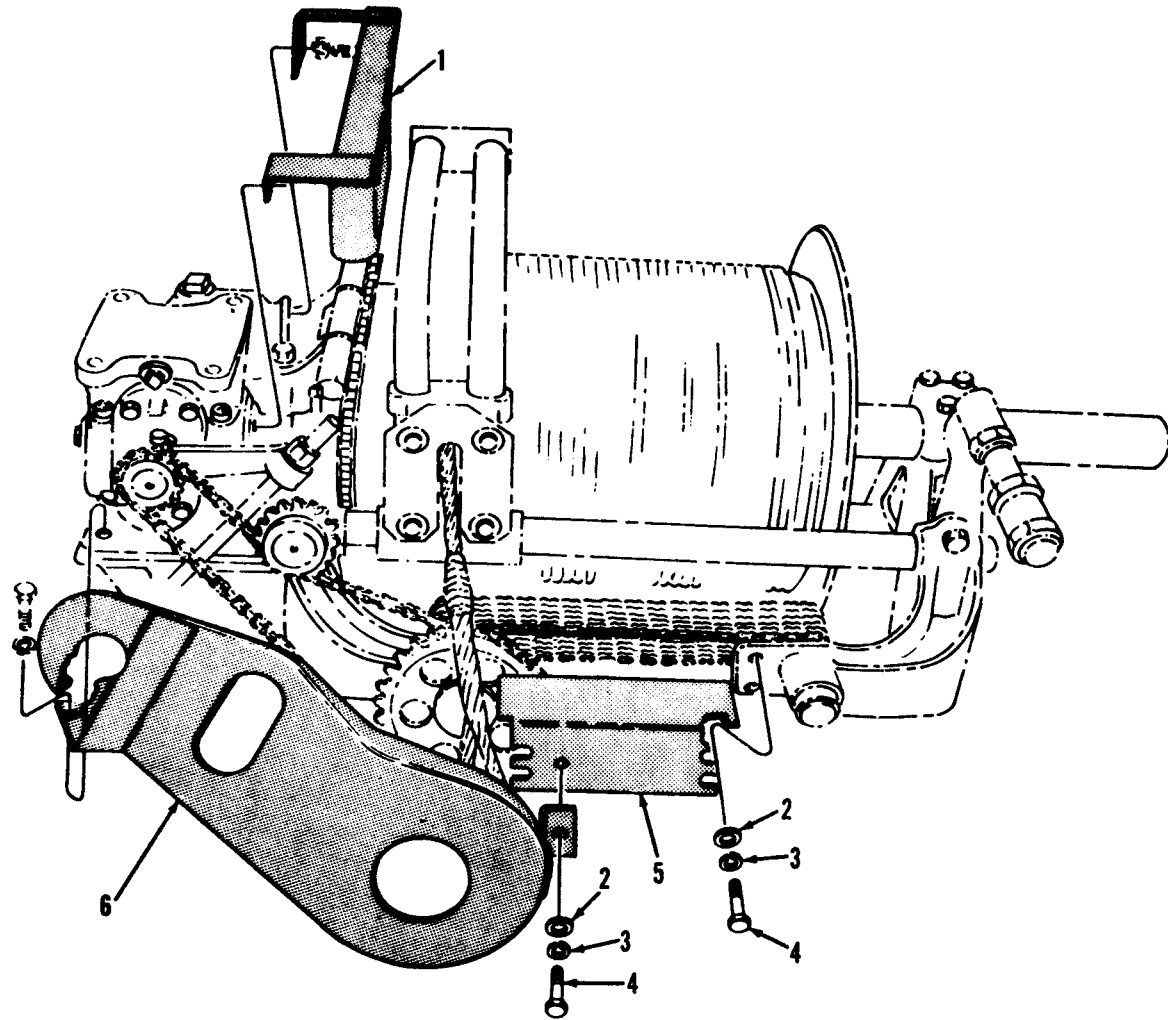

Figure 10. Rear winch drive chain idler pulley assembly—exploded view.



AT 40660

Figure 11. Chain covers—rear winch cable level winder.

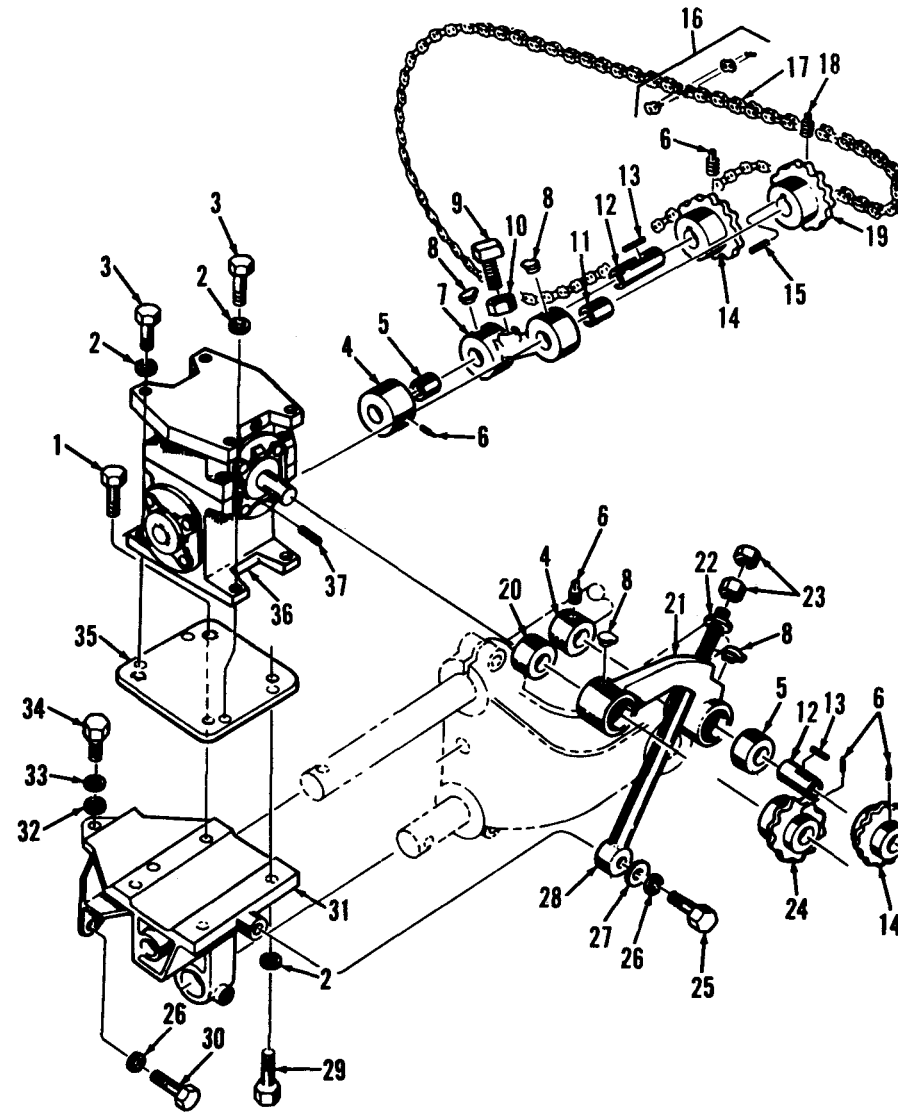

Figure 12. First and second reduction drive components—rear winch cable level winder—exploded view.



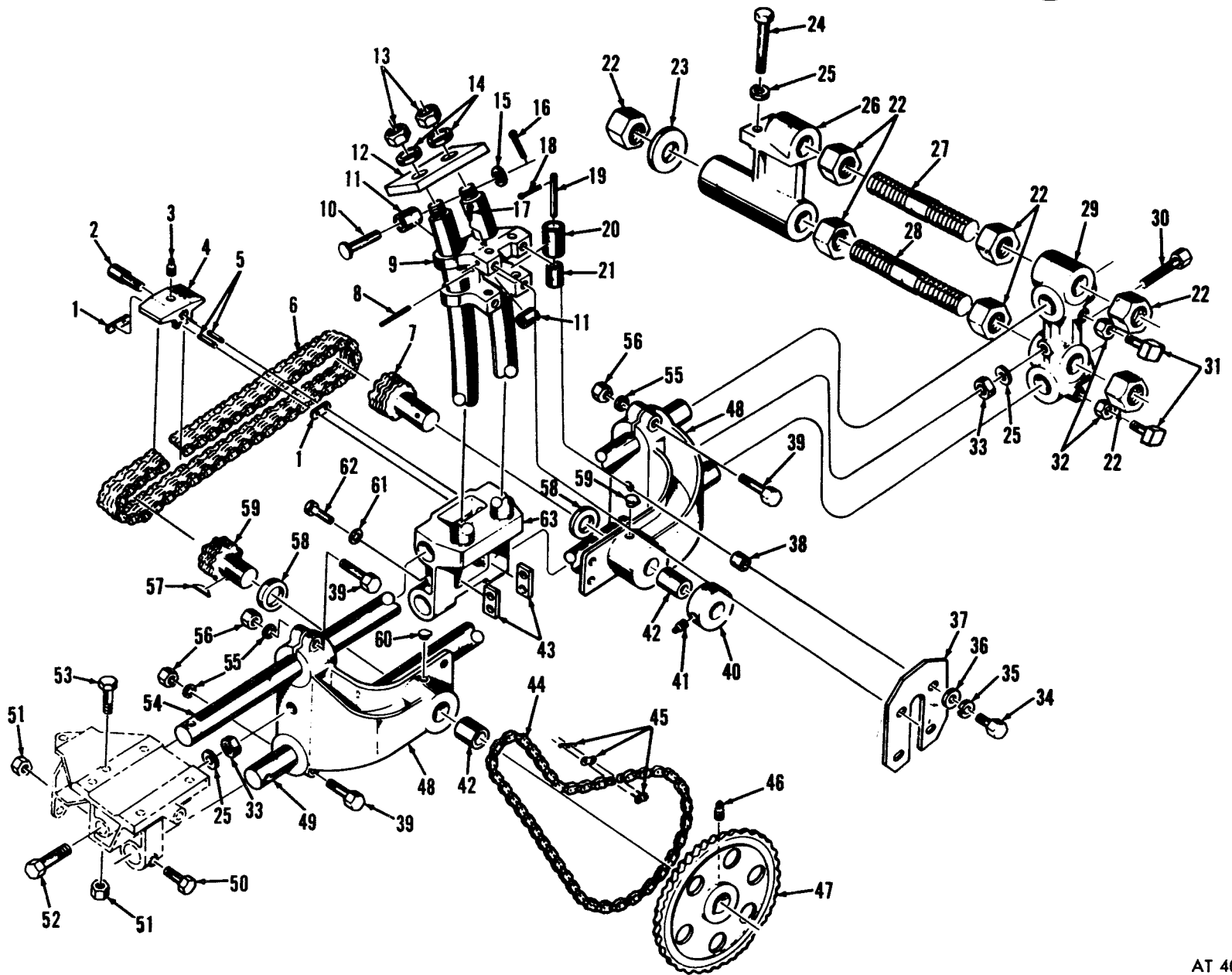

Figure 13. Carriage and tie rod support bracket assemblies—rear winch cable level winder  
—exploded view.

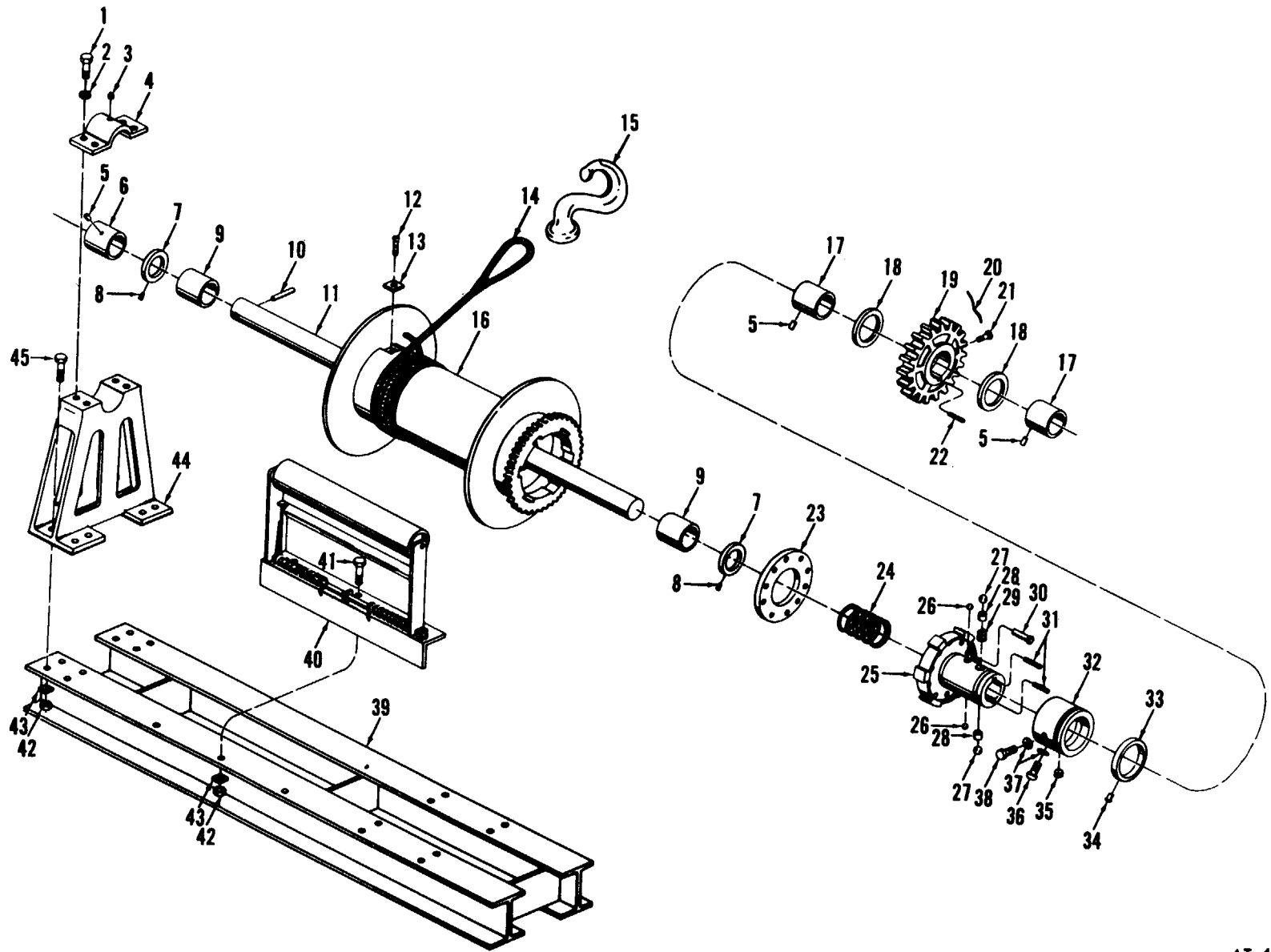

Figure 14. Rear winch drum and clutch assembly, wire rope and cable tensioner.

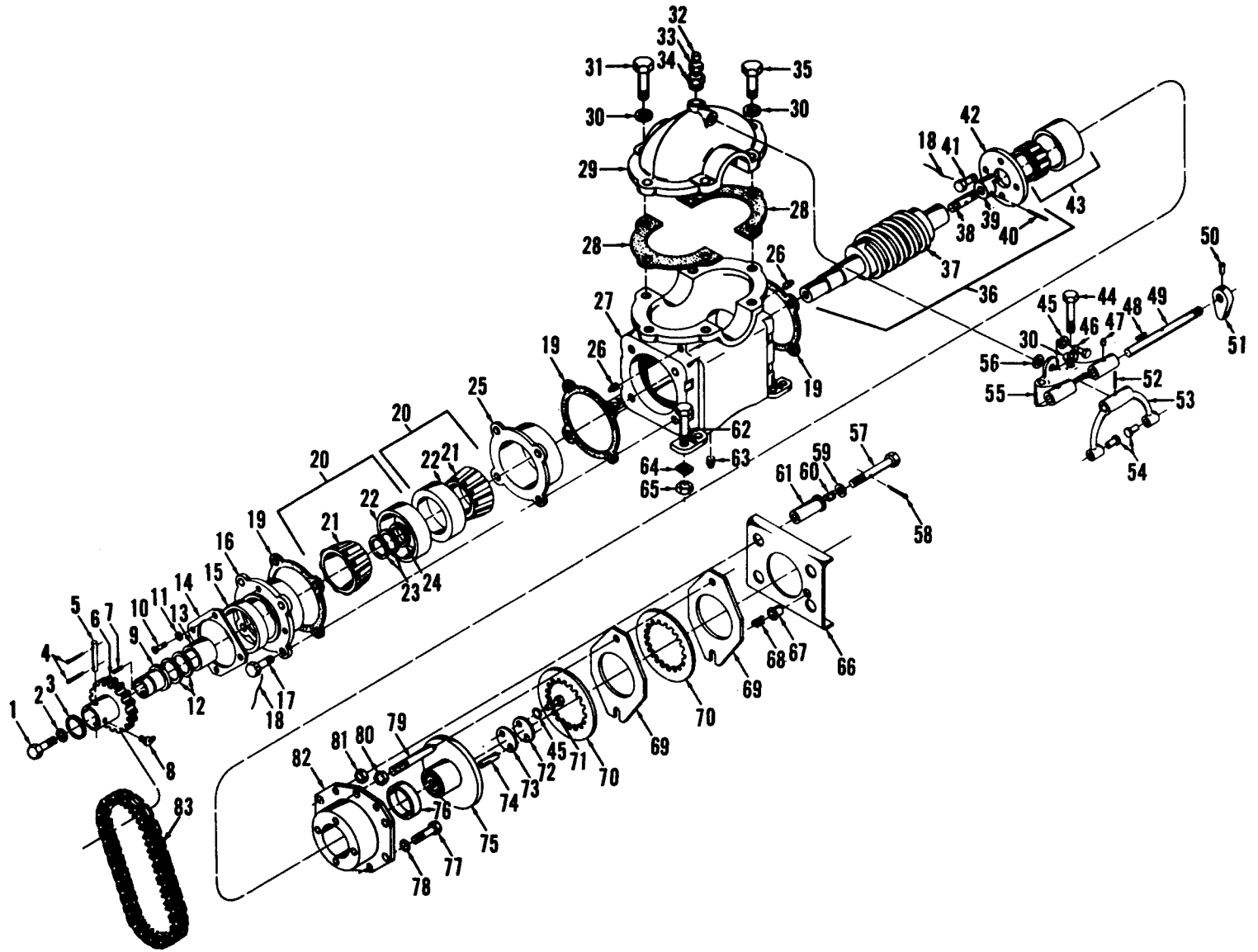

Figure 15. Rear winch drive chain, worm housing, and clutch and brake assemblies—exploded view.

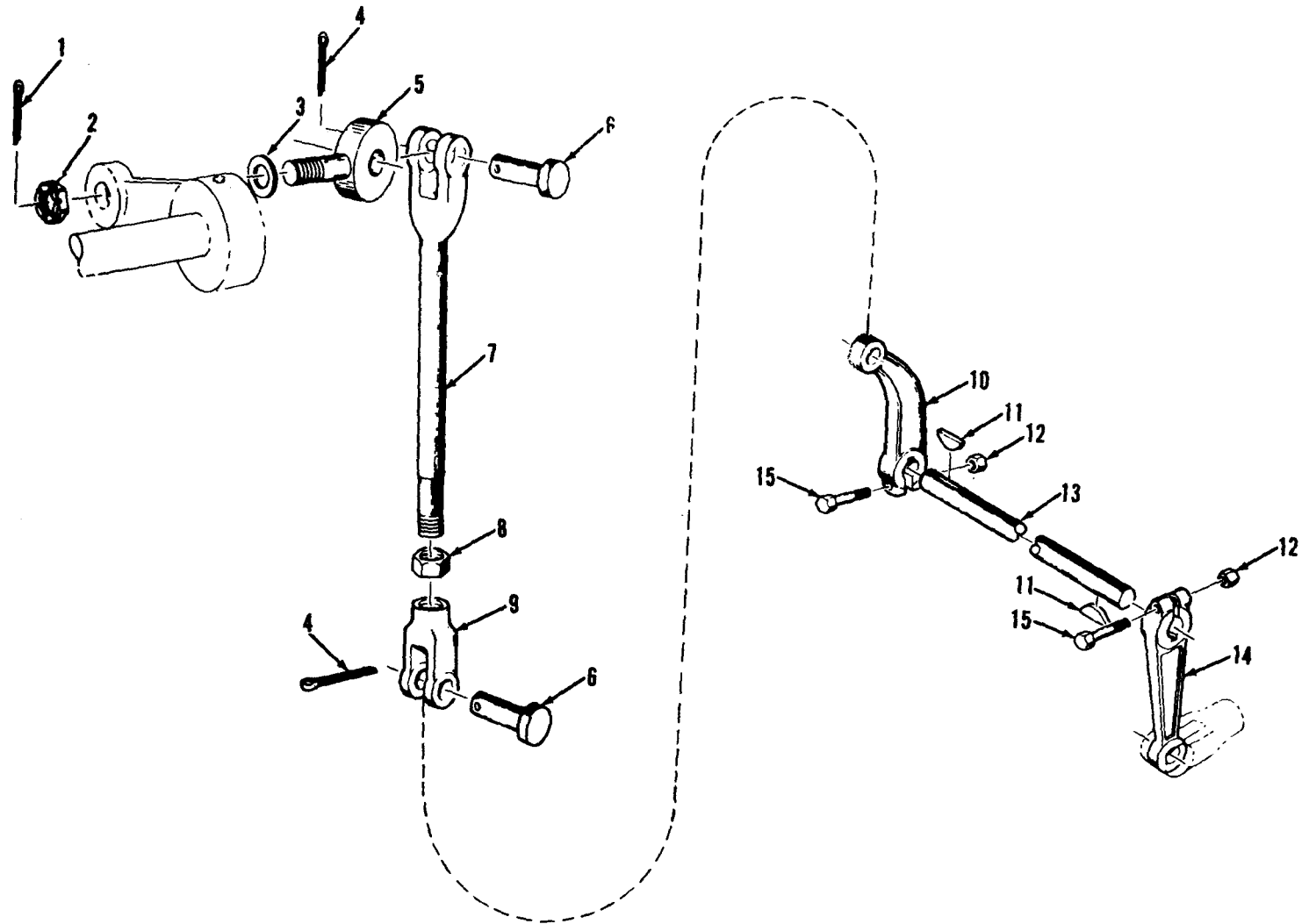
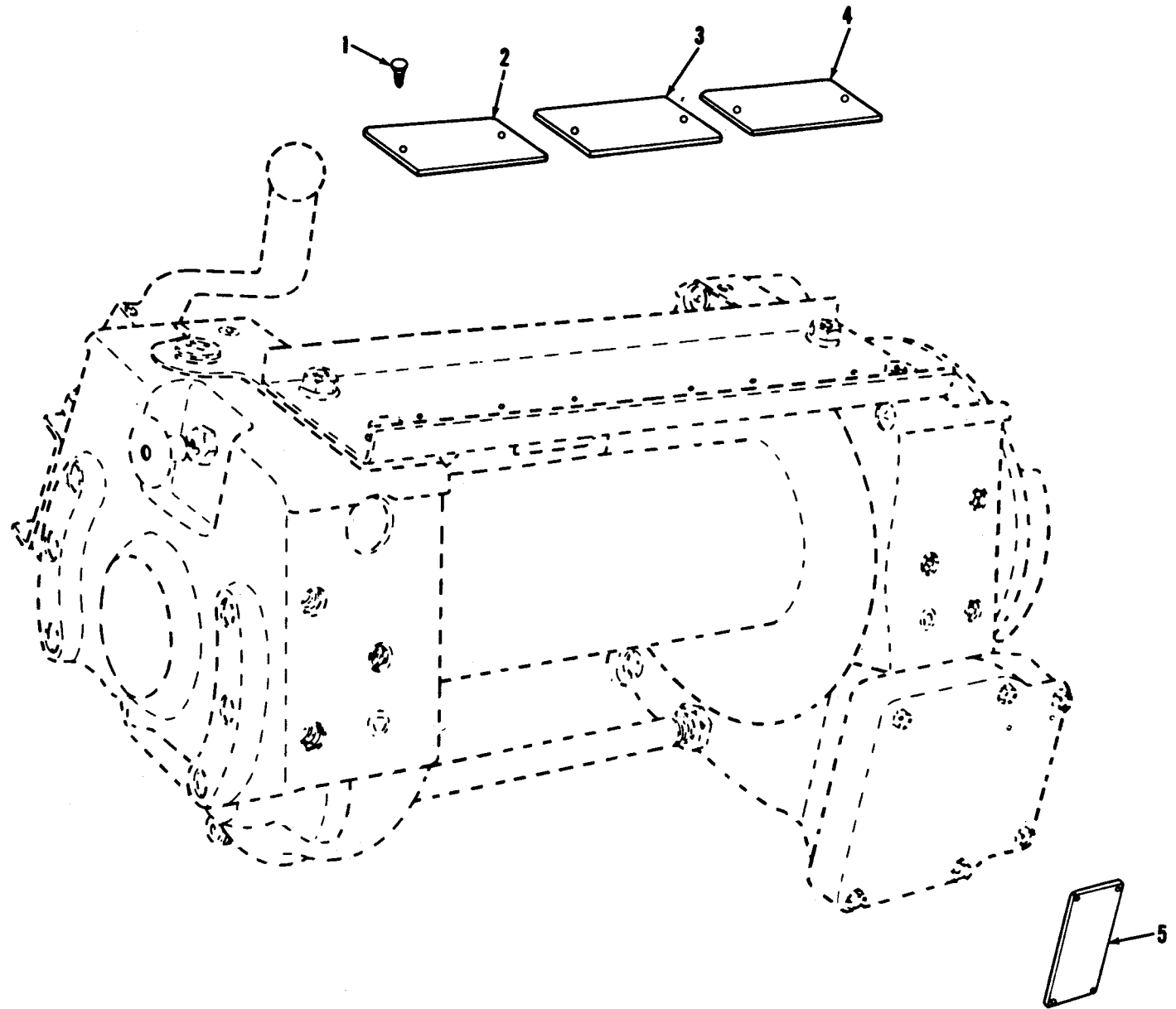

Figure 16. Rear winch control lever linkage—winch portion.



AT 40666

Figure 17. Instructions and data plates—front winch assembly (2590-753-8687).

## SECTION III

## FEDERAL STOCK NUMBER AND REFERENCE NUMBER INDEX

FEDERAL STOCK NUMBER	Federal Stock Number		Cross-Reference to Figure and		Item Number
	FIGURE NO	ITEM NO	FEDERAL STOCK NUMBER	FIGURE NO	ITEM NO
2520-032-2895	6	28	2590-443-4861	14	25
2520-032-2896	6	19	2590-489-2558	15	53
2520-040-2112	5	1	2590-634-5269	17	4
2520-318-0926	8	24	2590-693-0224	7	43
2520-318-0928	6	35		15	60
	8	6	2590-740-9727	3	19
2520-401-9548	15	36	2590-753-8687	1	1
2520-695-3342	3	37	2590-753-8701	2	31
2520-695-3350	3	26	2590-753-8703	3	31
2520-741-2651	2	11	2590-753-8706	3	4
2520-741-2652	3	28	2590-753-8727	3	40
2520-741-2656	3	33	2590-753-8734	3	15
2520-741-2745	2	19	2590-753-8793	17	3
2530-040-2110	8	39	2590-753-8892	2	25
2530-318-0916	7	34	2590-770-1738	6	38
	15	70		8	12
2530-321-6384	7	30		14	7
	15	68	2590-770-1749	7	12
2530-753-8730	2	27		15	19
2540-040-2105	6	23	2590-770-1753	7	10
2540-040-2108	7	38		15	28
2540-368-5015	4	4	2590-770-1761	8	23
2540-376-8205	7	27		14	18
2540-734-0527	8	18	2590-773-5940	8	15
2540-734-0528	8	31		14	23
2540-740-9150	3	2	2590-857-2750	2	1
2540-753-8690	3	29	2590-913-6879	17	2
2540-753-8697	2	39	2805-354-4160	8	40
2540-753-8698	2	14	3020-232-6016	13	47
2540-753-8699	2	44	3020-406-1480	12	19
2540-753-8700	3	44	3030-406-1482	12	14
2540-753-8702	3	25	3020-406-3417	13	58
2540-753-8707	2	20	3020-406-4585	15	6
2540-753-8708	3	16	3020-406-7290	13	7
2540-753-8726	3	38	3020-449-0517	12	24
2540-753-8729	3	11	3020-477-9880	10	4
2540-770-1017	7	22	3040-356-8615	16	13
2540-770-1746	14	19	3040-356-8619	14	11
2540-770-1754	7	13	3040-356-8695	15	49
2540-770-1755	7	36	3040-356-8707	12	12
2540-770-6879	7	45	3040-402-5189	15	51
2590-040-2126	6	17		16	14
2590-141-1619	17	5	3040-402-5190	16	10
2590-179-3442	3	47	3040-402-9579	13	40
2590-262-7572	3	35	3040-431-8340	12	4
2590-318-0930	7	13	3040-449-0528	16	7
2590-318-4299	2	24	3110-100-0599	7	47
2590-351-2838	13	43		15	22
2590-351-2839	13	4	3110-100-5817	15	20
2590-351-2847	7	28	3110-100-0800	6	10
	15	66	3110-100-0208	6	11
2590-351-2851	15	82	3110-100-6168	8	17
2590-351-2896	15	9	3110-142-4351	7	46
2590-402-5200	9	1	3110-142-4352	15	21
2590-406-1504	10	1	3110-144-8669	2	6
2590-406-1507	7	33	3110-183-9872	7	17
	15	69	3110-289-6824	10	2
2590-406-1508	15	75	3110-407-2777	7	49
2590-406-7296	14	40		15	16
2590-443-4860	15	39	3110-463-3882	15	42

Federal Stock Number Cross-Reference to Figure and Item Number					
FEDERAL STOCK NUMBER	FIGURE NO	ITEM NO	FEDERAL STOCK NUMBER	FIGURE NO	ITEM NO
3110-622-7035	8	16	5305-054-4471	8	34
3110-948-9796	3	20	5305-054-9286	13	31
3120-180-7755	13	42	5305-054-9307	10	13
3120-489-0355	12	5	5305-058-0761	13	17
3120-489-0354	12	11	5305-058-5022	12	9
3120-734-0526	6	24	5305-226-7768	6	37
	8	42	5305-253-5618	17	1
	14	6	5305-269-2801	12	1
3120-753-8696	2	12		15	71
	3	24	5305-269-2802	12	29
3120-753-8711	3	23	5305-269-2803	7	4
3120-770-1739	8	10		15	46
	14	9	5305-269-2804	12	3
3120-770-1750	8	22	5305-269-2807	13	62
	14	17	5305-269-2810	13	50
3030-242-5550	15	25	5305-269-2813	13	53
3830-318-0929	7	53	5305-335-4669	8	28
3830-321-6383	8	33		14	38
	14	13	5305-417-6579	6	3
3830-569-8664	8	19	5305-692-7128	8	26
3830-625-4418	2	26		14	21
3830-654-2166	8	20	5305-696-5074	8	9
	14	32	5305-696-5255	7	59
3830-699-6379	2	30	5305-715-1194	2	5
3830-752-9102	2	43		3	9
3830-753-8732	2	9	5305-716-8182	12	30
3830-770-1768	7	29		13	39
	15	67	5305-724-5833	12	18
3830-995-4357	7	51		13	46
3830-995-5821	8	13	5305-724-5896	12	6
3830-996-7394	7	8		13	3
4010-149-5619	4	5	5305-724-5910	10	10
4010-274-6816	4	2	5305-724-6810	13	41
4010-286-5646	4	6	5305-725-0166	3	36
4010-337-8278	4	7	5305-725-4098	15	35
4010-491-6990	14	14	5305-725-4105	14	1
4010-508-4700	4	1	5305-725-4111	12	34
4030-262-3152	4	3		15	31
4030-266-0066	4	9	5305-725-4133	13	24
4030-274-3464	4	8	5305-725-4152	15	44
4030-693-0649	14	15	5305-725-4183	7	20
4730-018-9566	3	6		14	41
4730-050-4208	6	18		15	77
	8	44	5305-725-4187	12	25
	14	3		14	45
	15	47		15	62
4730-172-0028	15	8	5305-727-8810	15	1
4730-202-6692	15	33	5305-782-9494	2	10
4730-221-2138	7	57	5305-782-9495	2	2
	15	26	5305-792-2864	15	41
4730-221-2139	7	25	5305-873-6946	3	46
	15	63	5305-948-9938	15	17
4730-278-3357	2	4	5305-984-7363	15	10
	3	8	5305-995-4332	7	31
4730-289-5176	8	27	5306-012-0741	2	33
	14	35	5306-018-7527	2	32
4820-726-4719	15	32	5306-109-4403	2	15
5305-012-3520	7	40	5306-207-2436	7	26
5305-012-5843	3	27		15	57
5305-012-6167	2	36	5306-225-9081	3	18
5305-042-6953	6	7	5306-225-9087	13	34
5305-044-5503	3	13	5306-225-9089	11	4

Federal Stock Number Cross-Reference to Figure and Item Number					
FEDERAL STOCK NUMBER	FIGURE NO	ITEM NO	FEDERAL STOCK NUMBER	FIGURE NO	ITEM NO
5306-225-9094	16	15	5310-823-8803	10	11
5306-464-4763	16	5		12	32
5306-753-8709	3	49	5310-834-8732	12	23
5306-753-8725	3	3	5310-834-8734	16	8
5306-753-8735	2	42	5310-835-2037	13	33
5310-017-8601	8	30	5310-842-1490	16	2
5310-021-4267	6	22	5310-842-7783	10	7
	7	32	5310-880-7744	3	1
	8	2	5310-891-3429	13	13
5310-021-9710	6	13	5310-933-8123	3	48
5310-022-5831	7	41	5310-975-2075	10	12
5310-045-1081	2	40	5310-982-4908	13	51
5310-067-9507	14	42	5310-984-3807	16	12
	15	65	5310-997-6903	13	22
5310-080-6004	15	59	5315-010-3362	6	33
5310-115-6869	6	2	5315-011-7869	14	5
5310-167-0680	2	16	5315-013-7214	13	18
5310-194-4791	10	5	5315-014-1240	3	43
5310-209-5116	14	37	5315-054-5552	6	25
5310-335-4667	7	38		8	32
5310-407-9566	2	34	5315-145-1872	15	40
	3	17	5315-145-1873	7	37
	11	3		15	74
	13	35	5315-198-5986	15	50
5310-409-4063	15	12	5315-252-5669	15	5
5310-489-0357	13	59	5315-264-3099	12	15
5310-499-0531	14	43	5315-281-7651	3	34
	15	64	5315-282-0328	7	1
5310-527-7972	2	35		15	54
5310-576-5752	15	11	5315-335-4492	8	37
5310-584-5272	2	3	5315-409-6583	14	10
	6	21	5315-433-2297	13	2
	7	19	5315-616-5522	2	21
	8	3	5315-616-5523	3	14
	12	26	5315-616-5527	13	57
	13	55	5315-616-5530	12	13
	15	78		16	11
5310-584-7888	13	14	5315-693-0216	7	23
	15	2	5315-696-0789	3	5
5310-595-6326	11	2	5315-732-0578	15	7
	13	36	5315-732-2835	15	48
5310-627-6128	7	39	5315-736-8685	2	17
5310-637-9541	7	5	5315-753-8333	2	18
	12	2	5315-781-2036	14	31
	13	61	5315-816-1794	13	16
	15	45	5315-824-2269	14	8
5310-732-0559	15	81	5315-839-5820	15	4
5310-732-0560	13	56	5315-839-5822	10	9
	15	80		16	4
5310-768-0318	12	10	5315-842-3044	15	58
	13	32		16	1
5310-770-1763	8	41	5315-842-3154	16	6
5310-809-3079	12	22	5315-951-8695	14	22
5310-809-4061	15	56	5315-990-2630	12	37
5310-809-5997	6	39	5320-010-4091	7	2
5310-809-5998	12	27	5320-012-1573	2	29
	13	15	5320-013-6593	8	14
	16	3	5320-051-8614	15	52
5310-820-6653	3	12	5320-058-2036	14	30
	7	58	5320-067-5840	14	34
	8	8	5320-264-3169	3	39
	12	33	5330-050-0156	7	56
	13	25		15	15
	14	2	5330-178-9237	15	76
	15	30	5330-179-0972	3	30



Federal Stock Number Cross-Reference to Figure and Item Number					
FEDERAL STOCK NUMBER	FIGURE NO	ITEM NO	FEDERAL STOCK NUMBER	FIGURE NO	ITEM NO
5330-196-2741	15	73	5340-573-3334	3	42
5330-286-7051	7	21	5360-448-5299	14	29
5330-286-7059	6	6	5365-159-2188	15	3
5330-286-8149	2	22	5365-252-5672	15	72
5330-291-1554	3	10	5365-491-9664	15	13
5330-640-9613	2	38	5365-995-8674	10	3
5330-695-1170	2	8	5995-999-4375	2	37
5330-696-0279	3	22		7	44
5330-753-8728	2	7	6130-896-1829	6	15
5330-753-8737	2	13	7310-999-2563	7	7
5340-050-1589	2	23	9505-248-9850	14	20
5340-054-1402	3	50		15	18
5340-177-3957	16	9			

NON-ILLUSTRATED

FEDERAL STOCK NUMBER	FUNCTIONAL GROUP	FEDERAL STOCK NUMBER	FUNCTIONAL GROUP
2530-741-2654	2001	2590-443-0102	2001
2530-753-8730	2001	4201-886-040	2001
2540-040-2107	2001	5320-012-1573	2001

## Federal Stock Number Cross-Reference To Figure and Item Number

REFERENCE NUMBER	MFG CODE	FIG NO	ITEM NO	REFERENCE NUMBER	MFG CODE	FIG NO	ITEM NO
AN6227-7	88044	2	38	MS27183-13	96906	11	2
HF-W2878C	74340	6	31			13	36
HG-W2883B	74340	6	20	MS27183-14	96906	15	59
HG-W2885A	74340	6	26	MS27183-15	96906	15	56
HG105E11	74340	6	4	MS27183-17	96906	6	40
HG110E27	74340	6	30	MS27183-18	96906	12	27
HG110E66	74340	7	48			13	15
HG110G27	74340	8	35			16	3
HG11067	74340	6	3	MS27183-19	96906	12	22
HG119E62	74340	7	15	MS27183-21	96906	10	11
HG119E66	74340	7	55			12	32
HG119E98	74340	6	8	MS35191-272	96906	15	10
HG125E45	74340	7	60	MS35249-163	96906	14	12
HG133E17	74340	7	50	MS35333-39	96906	15	11
HG142E62	74340	6	12	MS35335-37	96906	14	37
HG157A88	74340	7	11	MS35338-45	96906	2	34
HG176A34	74340	7	18			3	17
HG190A22	74340	6	14			11	3
HG216A97	74340	7	6			13	35
HG239B67	74340	7	3	MS35338-46	96906	7	5
HG250B79	74340	7	54			12	2
HG285B60	74340	6	16			13	61
HG31A587-2	74340	6	27			15	45
MS15003-1	96906	6	18	MS35338-48	96906	2	3
		8	44			6	21
		14	3			7	19
		15	47			8	3
MS15003-4	96906	15	8			12	26
MS150466	96906	14	26			13	55
MS150471	96906	14	27			15	78
MS16536-180	96906	14	30	MS35338-49	96906	2	16
MS16624-225	96906	15	3	MS35338-50	96906	3	12
MS16625-193	96906	10	3			7	58
MS17795-161	96906	13	42			8	8
MS17795-83	96906	13	21			12	33
MS19061-13	96906	3	20			13	25
MS19081-11	96906	10	2			14	2
MS20066-187	96906	12	15			15	30
MS20066-204	96906	15	7	MS35338-51	96906	13	14
MS20066-252	96906	12	37			15	2
MS20066-261	96906	15	48	MS35339-30	96906	3	48
MS20068-364	96906	14	22	MS35756-15	96906	12	13
MS20068-366	96906	14	31			16	11
MS20613-8P10	96906	14	34	MS35648-3	96906	2	23
MS20613-8P28	96906	15	52	MS35691-21	96906	10	12
MS20913-3S	96906	7	57	MS35691-33	96906	12	23
		15	26	MS35691-37	96906	16	8
MS20913-4S	96906	7	25	MS35691-53	96906	13	33
		15	63	MS35691-81	96906	13	13
MS20995F47	96906	14	20	MS35691-93	96906	13	22
		15	18	MS35692-37	96906	16	2
MS21045-6	96906	13	51	MS35692-53	96906	10	7
MS21318-27	96906	17	1	MS35756-11	96906	3	14
MS24665-134	96906	15	4	MS35756-18	96906	13	57
MS24665-145	96906	2	18	MS35810-36	96906	16	6
MS24665-283	96906	15	58	MS35812-11	96906	16	9
		16	1	MS49005-8	96906	14	35
MS24665-285	96906	13	16	MS51096-5	96906	15	41
MS24665-353	96906	10	9	MS51096-14	96906	15	17
		16	4	MS51922-13	96906	16	12
MS24665-359	96906	13	18	MS51922-37	96906	14	42
MS24692-38	96906	14	8			15	65
MS24692-331	96906	15	50	MS51955-5	96906	13	17

## Federal Stock Number Cross-Reference To Figure and Item Number

REFERENCE NUMBER	MFG CODE	FIG NO	ITEM NO	REFERENCE NUMBER	MFG CODE	FIG NO	ITEM NO
MS51955-72	96906	13	31	106751	50513	2	21
MS51955-79	96906	12	9	110E11	74340	7	31
MS51955-111	96906	10	13	11609808	19207	14	40
MS51963-82	96906	12	6	11609835	19207	14	16
		13	3	11609886	19207	15	5
MS51963-86	96906	12	18	11609887	19207	15	9
		13	46	11609888	19207	15	6
MS51963-101	96906	13	41	11609932-1	19207	13	6
MS51963-138	96906	3	36	11609932-3	19207	13	1
MS51967-5	96906	3	1	11621382	19207	12	4
MS51967-14	96906	12	10	11621385	19207	12	20
		13	32	11621386	19207	12	11
MS51968-8	96906	15	81	11621387	19207	12	5
MS51968-14	96906	13	56	11621388	19207	15	76
		15	80	11621389	19207	12	36
MS51981-80	96906	2	5	11621390	19207	15	43
		3	9	11622922	19207	15	75
MS90725-36	96906	3	18	11622948	19207	12	35
MS90725-111	96906	2	2	11622949	19207	12	28
MS90725-114	96906	2	10	11622951	19207	15	38
MS90725-160	96906	3	13	11622959	19207	15	24
MS90725-162	96906	10	10	11622962	19207	12	12
MS90726-32	96906	13	34	11622964	19207	15	36
MS90726-34	96906	11	4	11622965	19207	15	39
MS90726-39	96906	16	15	11622971	19207	15	14
MS90726-58	96906	12	1	11622974	19207	15	42
		15	71	11622978	19207	15	72
MS90726-59	96906	12	29	11622981	19207	15	27
MS90726-60	96906	7	4	11622986	19207	15	37
		15	46	11622990	19207	8	43
MS90726-61	96906	12	3			14	4
MS90726-64	96906	13	62	11622991	19207	14	44
MS90726-68	96906	13	50	11622999	19207	15	51
MS90726-69	96906	13	53	11623000	19207	14	28
MS90726-113	96906	14	41	11623002	19207	14	29
		15	77	11623004	19207	14	25
MS90726-114	96906	12	25	11623005	19207	15	55
		14	45	11623006	19207	14	24
		15	62	11623010	19207	15	53
MS90726-115	96906	6	37	11623011	19207	15	49
MS90726-117	96906	12	30	11623018	19207	14	39
		13	39	11623019	19207	14	11
MS90726-160	96906	15	35	11623020	19207	16	13
MS90726-164	96906	14	1	11623022	19207	14	10
MS90726-165	96906	12	34	11623023	19207	16	14
		15	31	11623024	19207	16	10
MS90726-168	96906	13	24	11623027	19207	13	37
MS90726-174	96906	15	44	11623028	19207	13	38
MS90726-185	96906	15	1	11623029	19207	13	20
MS90995F47	96906	15	18	11623030	19207	13	11
RMP-SC610LP	77667	6	32	11623031	19207	13	19
RMP-SC610SP	77667	6	34	11623032	19207	13	8
RRC271	81348	4	5	11623036	19207	13	9
RRC271TYPECLASSD	31548	4	8	11623040	19207	13	52
W2876C	74340	8	1	11623042	19207	12	21
W2877C	73362	8	39	11623045	19207	12	19
101W17	74340	8	11	11623046	19207	12	14
103362	92679	6	33	11623047	19207	12	24
103373	12204	7	27	11623048	19207	12	7
103387	21450	6	2	11623050	19207	13	48
103881	92679	2	4	11623052	19207	13	59
		3	8	11623053	19207	13	43
104091	24617	7	2	11623054	19207	13	5
104945	21450	3	39	11623055	19207	15	40

## Federal Stock Number Cross-Reference To Figure and Item Number

REFERENCE NUMBER	MFG CODE	FIG NO	ITEM NO	REFERENCE NUMBER	MFG CODE	FIG NO	ITEM NO
11623056	19207	13	40	145650	21450	8	17
11623057	19207	13	2	16476	24617	7	17
11623058	19207	13	4	165A47	74340	8	5
11623059	19207	13	7	178601	24617	8	30
11623060	19207	13	58	186969	21450	10	8
11623061	19207	13	47	187527	50513	2	32
11623062	19207	13	54	190A23	74340	6	1
11623064	19207	10	1	214267	21450	6	22
11623065	19207	10	4			7	32
11623067	19207	10	6			8	2
11623070	19207	10	5	219710	21450	6	13
11623073	19207	11	1	22R1365	19207	4	2
11623079	19207	11	6	22W1630	80244	7	14
11623084	19207	11	5	22W1631-110	80244	8	25
11623086	19207	13	23	2208436	24617	2	30
11623087	19207	13	30	221376	21450	6	25
11623088	19207	13	26			8	32
11623089	19207	13	29	225831	21450	7	41
11623090	19207	13	28	2286131	24617	3	31
11623091	19207	13	27	2286134	24617	2	42
11623121-1	19207	15	83	2286151	24617	2	27
11623125	19207	13	12	2286160	24617	3	26
11623128	19207	13	63	239B65	74340	8	20
11623130	19207	9	1			14	32
11623139-1	19207	13	44	239B66	73362	8	31
11623139-2	19207	12	16	305580	24076	3	42
		13	45	31A587-2	74340	8	4
11623139-3	19207	12	17	31324	80201	6	6
11623232	19207	13	49	426953	21450	6	7
11623234	19207	12	31	429730	21450	8	9
11623368	19207	15	25	429739	21450	7	61
11623816	19207	14	14	430114	21450	7	59
117869	21450	14	5	437857	21450	8	29
119E65	74340	7	51	439534	21450	14	36
119E69	74340	7	52	444703	24617	8	27
120234	21450	7	20	451081	21450	2	40
120235	64104	8	40	500094	24617	2	22
120394	13190	2	37	500117	21450	7	21
		7	44	500156	21450	7	56
120728	24617	7	47			15	15
120741	50513	2	33	500261	19207	3	30
121573	24617	2	29	505006	21450	13	10
123E41	74340	8	21	505761	97297	7	7
		14	33	507402	21450	4	9
123E43	74340	8	13	5196397	19207	15	32
123E20	50513	7	40	5277972	19207	2	35
125843	24617	3	27	541402	21450	3	51
126167	50513	2	36	542695	05869	6	15
127S23	74340	7	8	544471	21450	8	34
127956	19207	15	33	607563	24617	6	24
133870	21450	2	41			8	42
136593	21450	8	14			14	6
137178	24617	7	46	607594	24617	8	18
138489	21450	7	39	607596	24617	8	16
139194	21450	3	45	700338	21450	2	6
139416	21450	6	36	703162	19207	15	20
		8	7	705023	21450	6	11
139747	21450	3	7	705527	19207	15	21
140771	21450	12	8	706915	19207	15	22
		13	60	707067	21450	6	10
141240	50513	3	43	7071882	19207	4	3
142E44	74340	6	9	7097160	19207	15	79
144057	21450	15	34	7340523	19207	8	37

## Federal Stock Number Cross-Reference To Figure and Item Number

REFERENCE NUMBER	MFG CODE	FIG NO	ITEM NO	REFERENCE NUMBER	MFG CODE	FIG NO	ITEM NO
7340529	19207	8	19	7701739	19207	8	10
7367930	19207	7	23			14	9
7367933	19207	8	38	7701745	19207	7	9
7368186	19207	8	26			15	29
		14	21	7701746	19207	14	19
7368685	19207	2	17	7701749	19207	7	12
7374022	19207	15	23			15	19
7374026	19207	16	7	7701750	19207	8	22
7409150	19207	3	2			14	17
7412651	19207	2	11	7701751	19207	7	43
7412652	19207	3	28			15	60
7412656	19207	3	33	7701752	19207	7	26
7412745	19207	2	19			15	57
7529100	19207	3	21	7701753	19207	7	10
7529101	19207	2	1			15	28
7529102	19207	2	43	7701754	19207	7	13
7538687	19207	1	1	7701755	19207	7	36
7538688	19207	3	35	7701757	19207	15	13
7538690	19207	3	29	7701761	19207	8	23
7538691	19207	3	37			14	18
7538694	19207	3	22	7701763	19207	8	41
7538695	19207	3	10	7701768	19207	7	29
7538696	19207	2	12	7701768	19207	15	67
		3	24	7706879	19207	7	45
7538697	19207	2	39	7717007	19207	4	7
7538698	19207	2	14	7717030	19207	4	4
7538699	19207	2	44	7727462	19207	14	43
7538700	19207	3	44			15	64
7538701	19207	2	31	7734926	19207	7	42
7538702	19207	3	25			15	61
7538704	19207	2	8	7735524	19207	15	73
7538706	19207	3	4	7735927	19207	7	35
7538707	19207	2	20	7735940	19207	8	15
7538708	19207	3	16			14	23
7538709	19207	3	49	7954459	19207	3	41
7538710	19207	2	15	7994966	19207	17	4
7538711	19207	3	23	8328119	19207	7	38
7538722	19207	3	19	8328120	19207	7	34
7538725	19207	3	3			15	70
7538726	19207	3	38	8328341	19207	3	34
7538727	19207	3	40	8329780	19207	6	23
7538728	19207	2	7	8329791	19207	6	28
7538729	19207	3	11	8329792	19207	6	19
7538731	19207	2	26	8329793	19207	8	33
7538732	19207	2	9			14	13
7538733	19207	3	46	8329794	19207	8	24
7538734	19207	3	15	8329797	19207	7	38
7538737	19207	2	13	8329798	19207	7	1
7538793	19207	17	3			15	54
7538892	19207	2	25	8329799	19207	7	37
7540181	19207	6	29			15	74
		7	24	8329800	19207	7	33
		8	36			15	69
7540183	19207	16	5	8329801	19207	7	28
7701015	19207	15	12			15	66
7701017	19207	7	22	8329802	19207	8	28
7701019	19207	15	82			14	38
7701025	19207	7	49	8329804	19207	7	30
		15	16			15	68
7701026	19207	7	16	8329805	19207	6	5
7701738	19207	6	38	8329806	19207	6	35
		8	12			8	6
		14	7	8329807	19207	7	53

Federal Stock Number Cross-Reference To Figure and Item Number

REFERENCE NUMBER	MFG CODE	FIG NO	ITEM NO	REFERENCE NUMBER	MFG CODE	FIG NO	ITEM NO
8329808	19207	5	1	8690290	19207	2	28
8329809	74340	7	13	8690899	19207	17	2
8329866	19207	6	17	9690900	19207	17	5
8330519	19207	3	32	8710655	19207	3	47
8332403	19207	14	15	8723828	19207	3	5
8333643	19207	2	24				

NON-ILLUSTRATED

REFERENCE NUMBER	MFG CODE	FUNCTIONAL GROUP	REFERENCE NUMBER	MFG CODE	FUNCTIONAL GROUP
121573	24617	2001	5704138	19207	2001
2286151	24617	2001	7412654	19207	2001
42C18860-40	80244	2001	8329796	19207	2001

**BY Order of the Secretary of the Army:**

**W. C. WESTMORELAND,**  
*General, United States Army,*  
*Chief of Staff.*

**Official :**

**VERNE L. BOWERS,**  
*Major General, United States Army,*  
*The Adjutant General.*

**Distribution:**

To be distributed in accordance with DA Form 12-38 (qty rqr block No. 35) direct and general support maintenance requirements for Trucks, Cargo, 2 1/2 Ton, M35A2.







